

**TM 11-5820-765-34**

**TECHNICAL MANUAL**

**DIRECT SUPPORT AND GENERAL SUPPORT  
MAINTENANCE**

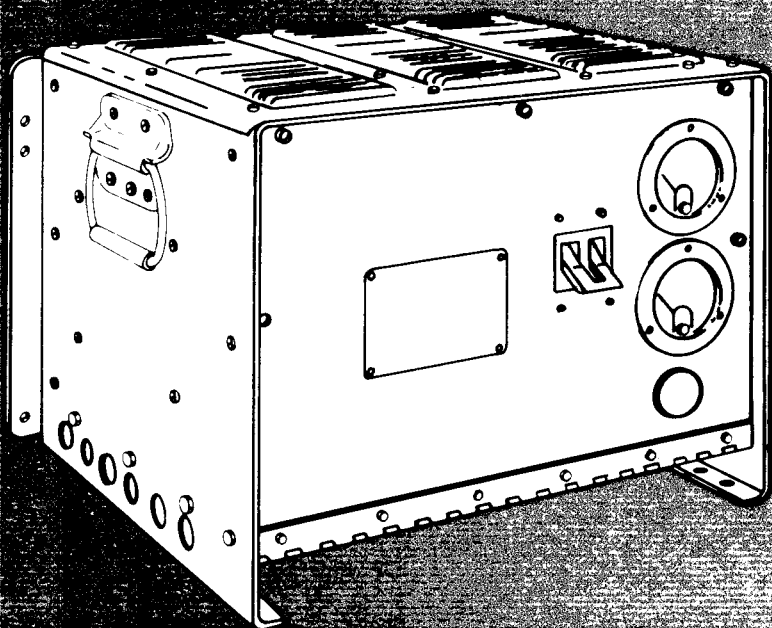

**EQUIPMENT DESCRIPTION**

**Page 1-3**

**TECHNICAL PRINCIPLES  
OF OPERATION**

**Page 1-7**

**DIRECT SUPPORT  
MAINTENANCE**

**Page 2-0**

**TROUBLESHOOTING**

**Page 2-4**

**MAINTENANCE  
PROCEDURES**

**Page 2-22**

**TEST PROCEDURES**

**Page 2-43**

**GENERAL SUPPORT  
MAINTENANCE**

**Page 3-1**

**TROUBLESHOOTING**

**Page 3-4**

**MAINTENANCE  
PROCEDURES**

**Page 3-7**

**TEST PROCEDURES**

**Page 3-11**

**POWER SUPPLIES**

**PP-4763/GRC (NSN 5820-00-937-7690)**

**AND**

**PP-4763A/GRC (NSN 5820-00-113-9768)**

**HEADQUARTERS, DEPARTMENT OF THE ARMY**

**15 AUGUST 1963**



5

## SAFETY STEPS TO FOLLOW IF SOMEONE IS THE VICTIM OF ELECTRICAL SHOCK

1

DO NOT TRY TO PULL OR GRAB THE INDIVIDUAL

2

IF POSSIBLE, TURN OFF THE ELECTRICAL POWER

3

IF YOU CANNOT TURN OFF THE ELECTRICAL POWER, PULL, PUSH, OR LIFT THE PERSON TO SAFETY USING A WOODEN POLE OR A ROPE OR SOME OTHER INSULATING MATERIAL

4

SEND FOR HELP AS SOON AS POSSIBLE

5

AFTER THE INJURED PERSON IS FREE OF CONTACT WITH THE SOURCE OF ELECTRICAL SHOCK, MOVE THE PERSON A SHORT DISTANCE AWAY AND IMMEDIATELY START ARTIFICIAL RESUSCITATION



LOW VOLTAGE, HIGH-AMPERAGE CURRENT IS PRESENT AT OUTPUT CONNECTIONS  
AND CONNECTIONS INSIDE EQUIPMENT.

SHUT OFF POWER SUPPLY BEFORE PERFORMING MAINTENANCE.

DISCHARGE CAPACITORS BEFORE PERFORMING TESTS AND MAINTENANCE.

BE CAREFUL WHEN WORKING WITH AC LINE CONNECTIONS.

SERIOUS INJURY OR DEATH MAY RESULT FROM CONTACT WITH TERMINALS.

**DO NOT SERVICE OR ADJUST ALONE**

Do not attempt internal service or adjustment unless another person, capable of rendering first aid and resuscitation, is present.

**SAFETY PRECAUTION**

A periodic review of safety precautions in TB 385-4, Safety Precautions for Maintenance of Electrical/Electronic Equipment, is recommended. When the equipment is operated with covers removed, DO NOT TOUCH exposed connections or components. MAKE CERTAIN you are not grounded when making connections or adjusting components inside the test instrument.

**TRICHLOROTRIFLUOROETHANE**

Adequate ventilation should be provided while using TRICHLOROTRIFLUOROETHANE. Prolonged breathing of vapor should be avoided. The solvent should not be used near heat or open flame; the products of decomposition are toxic and irritating. Since TRICHLOROTRIFLUOROETHANE dissolves natural oils, prolonged contact with skin should be avoided. When necessary, use gloves which the solvent cannot penetrate. If the solvent is taken internally, consult a physician immediately.

**PROTECTIVE COATING EC1103 IS TOXIC.  
USE PROPER VENTILATION: AVOID BREATHING FUMES.  
AVOID CONTACT WITH SKIN.**

**HEAVY EQUIPMENT**

Don't take chances. Avoid personal injury. These equipments are heavy. They weigh 100-125 pounds. Use four persons to lift.

A/(B BLANK)



**DIRECT SUPPORT AND GENERAL SUPPORT  
MAINTENANCE MANUAL**

**POWER SUPPLIES**

**PP-4763/GRC (NSN 5820-00-937-7690)**

**AND**

**PP-4763A/GRC (NSN 5820-00-113-9768)**

**REPORTING ERRORS AND RECOMMENDING IMPROVEMENTS**

You can help improve this manual. If you find any mistakes or if you know of a way to improve the procedures, please let us know. Mail your letter, DA Form 2028 (Recommended Changes to Publications and Blank Forms), or DA Form 2028-2 located in back of this manual direct to: Commander, US Army Communications-Electronics Command and Fort Monmouth, ATTN: DRSEL-ME-MP, Fort Monmouth, New Jersey 07703. A reply will be furnished direct to you.

**TABLE OF CONTENTS**

	PAGE
CHAPTER 1 INTRODUCTION .....	1-0
Section I General Information .....	1-2
Section II <b>Equipment Description and Data</b> .....	1-2
Section III <b>Technical Principles of Operation</b> .....	1-5
CHAPTER 2 <b>DIRECT SUPPORT MAINTENANCE</b> .....	2-0
Section I General Information .....	2-1
Section II <b>Troubleshooting</b> .....	2-2
Section III <b>Maintenance Procedures</b> .....	2-22
Section IV <b>Test Procedures</b> .....	2-44
CHAPTER 3 <b>GENERAL SUPPORT MAINTENANCE</b> .....	3-1
Section I General Information .....	3-2
Section II <b>Troubleshooting</b> .....	3-3
Section III <b>Maintenance Procedures</b> .....	3-6
Section IV <b>Test Procedures</b> .....	3-10
APPENDIX A REFERENCES .....	A-1
APPENDIX B EXPENDABLE SUPPLIES AND MATERIALS LIST. ....	B-1
INDEX .....	Index-1
FOLDOUT INDEX .....	Foldout Index-1

\*This manual supersedes TM 11-5820-765-35, 15 June 1969.

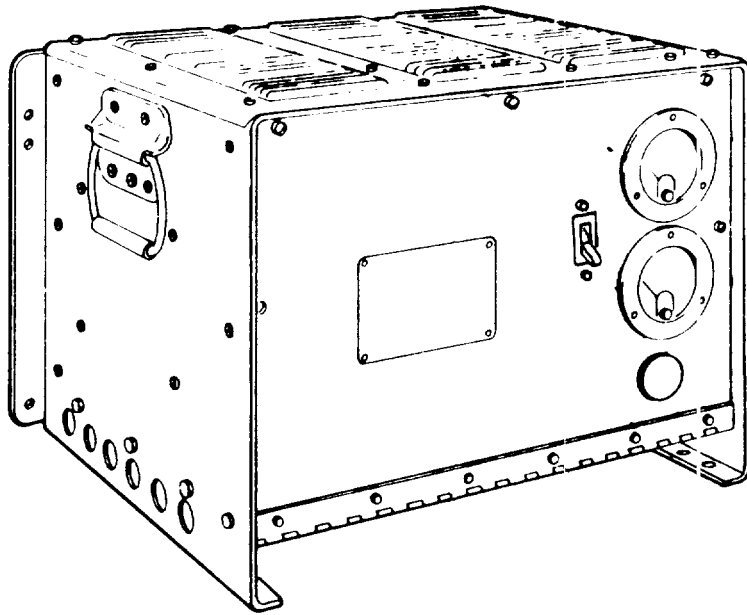

PP-4763/GRC

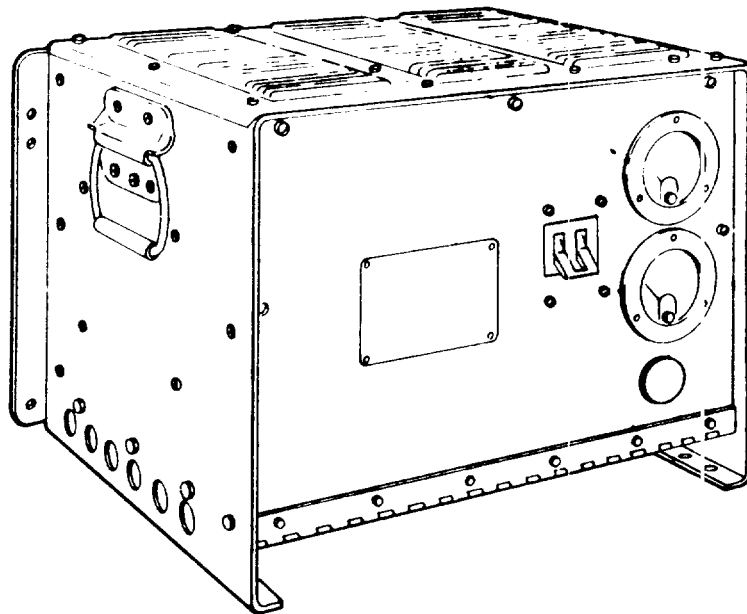

PP-4763A/GRC

**CHAPTER 1**  
**INTRODUCTION**

**Section I. GENERAL INFORMATION**

	PAGE
Destruction of Army Materiel to Prevent Enemy Use . . . . .	1-2
Maintenance Forms, Records and Reports . . . . .	1-2
Reporting Equipment improvement Recommendations (EIR) . . . . .	1-2
Scope . . . . .	1-2
Technical Characteristics . . . . .	1-2

**Section II. EQUIPMENT DESCRIPTION AND DATA**

Differences Between Models. . . . .	1-3
PowerSupplyConnectionsto Radio Set AN/GRC-106 . . . . .	1-4
Purpose and Use . . . . .	1-2
Safety, Care, and Handling . . . . .	1-4

**Section III. TECHNICAL PRINCIPLES OF OPERATION**

Block Diagram Analysis . . . . .	1-5
Control Circuits . . . . .	1-8
Powerand Voltage Circuits. . . . .	1-6

## Section I. GENERAL INFORMATION

### 1-1. SCOPE

This manual describes direct and general support maintenance for Power Supply PP-4763/GRC and Power Supply PP-4763A/GRC. It includes instructions for troubleshooting, repairing, and testing the equipment. It also lists all the tools, test equipment, and materials needed for maintenance.

The power supplies and their major electronic components are described in section II of this chapter. Operating instructions and organizational maintenance are covered in TM 11-5820-765-12.

#### NOTE

In this manual, Power Supplies PP-4763/GRC and PP-4763A/GRC are referred to as power supply (\*). Specific models are identified by unit nomenclature, without the GRC designation.

### 1-2. MAINTENANCE FORMS, RECORDS, AND REPORTS

Department of the Army forms and procedures used for equipment maintenance will be those prescribed by TM 38-750, The Army Maintenance Management System (TAMMS).

### 1-3. DESTRUCTION OF ARMY MATERIEL TO PREVENT ENEMY USE

Destruction of Army electronics materiel to prevent enemy use shall be in accordance with TM 750-244-2.

### 1-4. REPORTING EQUIPMENT IMPROVEMENT RECOMMENDATIONS (EIR)

If your Power Supplies PP-4763/GRC and PP-4763A/GRC need improvement, let us know. Send us an EIR. You, the user, are the only one who can tell us what you don't like about your equipment. Let us know why you don't like the design. Put it on an SF 368 (Quality Deficiency Report). Mail it to Commander, US Army Communications-Electronics Command and Fort Monmouth, ATTN: DRSEL-ME-MP, Fort Monmouth, New Jersey 07703. We'll send you a reply.

### 1-5. TECHNICAL CHARACTERISTICS

See TM-11-5820-765-12, paragraph 1-5.

## Section II. EQUIPMENT DESCRIPTION AND DATA

### 1-6. EQUIPMENT CHARACTERISTICS, CAPABILITIES AND FEATURES

The power supplies function in the same way. Both provide a dc power source for communications equipment, or for any type of load with similar power requirements.

PP-4763 converts 115 volts alternating current (ac) to direct current (dc) at a selected regulated voltage.

PP-4763A converts either 115 or 230 volts alternating current (ac) to direct current (dc) at a selected regulated voltage.



1-7. DIFFERENCES BETWEEN MODELS

Differences Between Parts

Item	PP-4763	PP-4763A
AC power option	115 volts ac, $\pm 10\%$ , 47-63 Hz.	115 or 230 volts ac, $\pm 10\%$ , 47-63 Hz.
AC power cable W3	Provided with terminal lug for each wire connection to ac power source.	Provided with locking prongs on plug for connection to ac power source.
AC power switch CB1	Single switch circuit breaker.	Double switch circuit breaker.
DC output connections	Terminal board A8-cable attached to connect dc output to equipment under test.	Cable from equipment under test connected either to terminal board A8 or to receptacle J1.
Terminal board TB1	Provides connections for transformer T1.	Provides connections for transformer T-1 and for 115-volt ac/230-volt ac links.
Reactor L3 (choke)	Not provided	Provided
Top cover interlock switch S1	Not provided	Provided; disconnects ac input power when top cover is removed.
Test jacks (on circuit card assembly)	Not provided	Test jacks TP1 through TP6 provided.

Differences Between Reference Designations

Most parts used in both power supplies have one reference designation.

EXAMPLE:

Voltmeter is designated MI in both power supplies.

The following parts have different reference designations:

	PP-4763	PP-4763A
Circuit card assembly	PC101	A1
Rectifier bridge (on circuit card assembly)	z	No designation
RFI filter	FL	z
Silicon controlled rectifier	SCR	Q

For these parts, parentheses indicate designations for PP-4763A.

EXAMPLE:

Circuit card assembly appears in text as PC101(A1).

**WARNING**  
HEAVY EQUIPMENT

Don't take chances. Avoid personal injury. These equipments are heavy. They weigh 100-125 pounds. Use four persons to lift.

**1-8. SAFETY, CARE, AND HANDLING**

Be careful when lifting the equipment. PP-4763 weighs 120 pounds and PP-4763A weighs 125 pounds. When packed for shipment, each unit weighs about 200 pounds. Use four persons to remove unit from shelter. Carry by both handles at all times. Read all WARNINGS, CAUTIONS, and NOTES. Think safety!

**1-9. POWER SUPPLY CONNECTIONS TO RADIO SET AN/GRC-106**

**Power Connections**

**Cable Assembly, Power Electrical CX-10071/U (10 ft.)**

Connects dc output terminals at rear of power supply to following components of Radio Set AN/GRC-106:

**Amplifier, Radio Frequency AM-3349/GRC-106**

**Receiver-Transmitter, Radio RT-662/GRC (see TM 11-5820-520-10)**

**Power Cabling**

Cable Assembly, Special Purpose, Electrical CX-11899/U (from Interconnecting Kit, Power MK-1162/GRC).

Connects dc output terminals of power supply to AN/GRC-106 components.

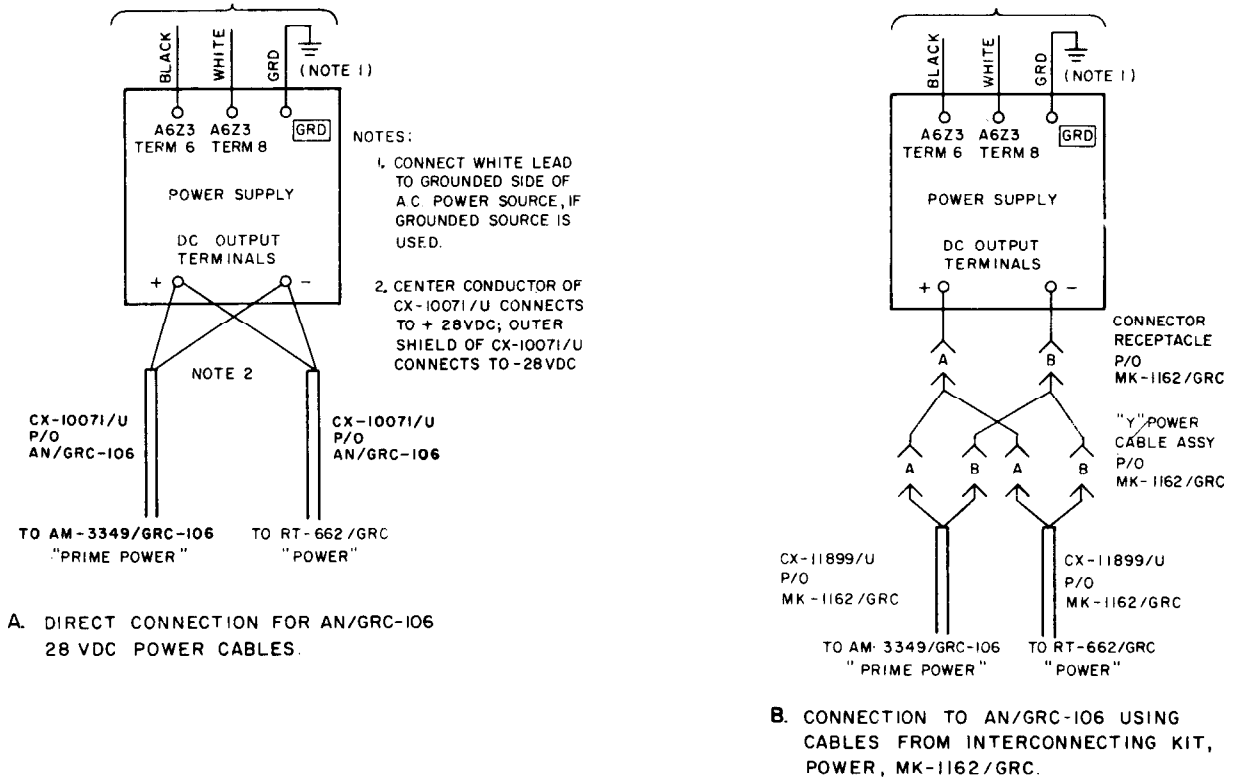

Section III. TECHNICAL PRINCIPLES OF OPERATION

1-10. BLOCK DIAGRAM ANALYSIS

The block diagram describes the power supply's major electronic components and circuits.

The power supply requires an input of 115 volts ac or 230 volts ac for operation, and has an output of 27-29 volts dc.

Input power: Applied through a radio frequency interference (RFI) filter to the circuit breaker. With the circuit breaker closed (POWER ON), input power flows to the power transformer, which feeds the fan motor, circuit card assembly, and all of the power supply's circuits.

Output: The transformer applies power through a reactor to a full-wave bridge rectifier, which converts the input flow to dc. A silicon controlled rectifier regulates the dc output; control circuitry in the circuit card assembly provides automatic, continuous voltage regulation. A filter network purifies the dc signal; the regulated positive dc output flows through the output current meter (ammeter) and is shunt to the dc output terminal.

A voltage adjust circuit permits manual adjustment of the output voltage; controls in the circuit card assembly sense the adjustment and change the voltage.

An overvoltage circuit, activated when needed, applies a short-circuit load to the output terminals, opening the circuit breaker. This protects the power supply and the equipment being powered.

The output voltage meter (voltmeter) monitors output voltage, which passes again through the RFI filter before reaching the dc output terminal.

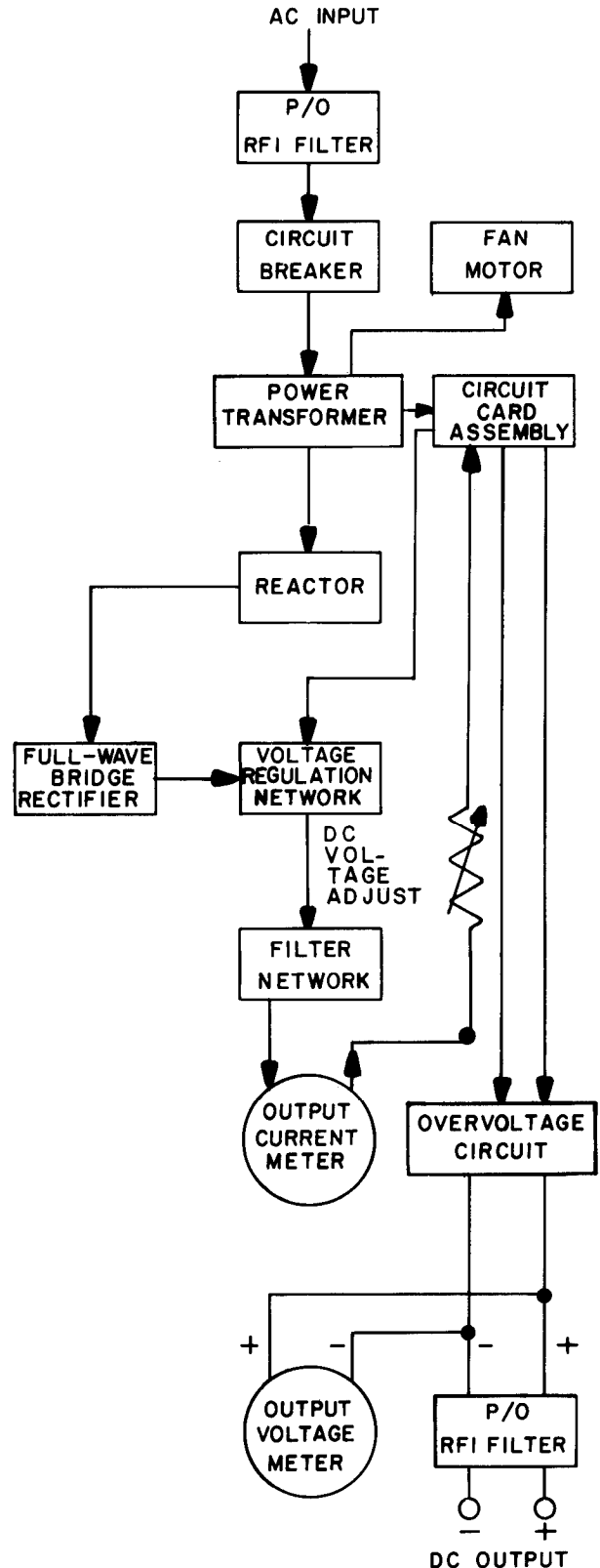

## 1-11. POWER AND VOLTAGE CIRCUITS

### POWER CIRCUITS

#### PP-4763

CIRCUIT BREAKER CB1 (refer to FO-2):

- Single ac power switch.
- Turns power supply ON, OFF.
- Protects against overloading power supply.
- Power ON: Connects 115-volt ac source to primary winding, power transformer T-1, and to fan motor B1.

#### PP-4763A

CIRCUIT BREAKER CB1 (refer to FO-3):

- Dual ac power switch.
- Turns power supply ON, OFF.
- In series with both legs of ac input power.
- Power ON: Connects either 115-or 230-volt ac source to primary winding, power transformer T1, and to fan motor B1.

SAFETY INTERLOCK SWITCH S1:

- Opens input power circuit when unit's top panel is removed.
- This is a protective control.

### Functional Analysis of Power Circuit Parts

TRANSFORMER T1:

Secondary winding:

- Power secondary supplies full-wave bridge rectifier (rectifier diodes CR1, CR2, CR3, and CR4).
- Two control secondaries supply circuit card assembly PC101 (AI).

SILICON CONTROLLED RECTIFIER SCR1 (Q1):

- Connected in bridge rectifier outlet.
- Regulates dc output.

REACTOR L2:

- Connected in ac supply to bridge rectifier.
- Introduces time delay needed to operate SCR1 (Q1).

DIODE CR5:

- Connected across bridge rectifier's output.
- Provides discharge path for filter reactor L1.
- Prevents continued firing of SCR1 (Q1).

BLEEDER RESISTORS R1, R10:

- Connected across bridge rectifier's output.
- Stabilize power supply's operations during low-load conditions.

### NOTE

PP-4763A includes choke L3 in series with R10.

**VOLTAGE SURGE PROTECTOR DIODE CR6:**

- Connected across transformer's power secondary winding.
- Protects voltage regulator rectifier SCR1 (Q1) and bridge rectifier diodes CR1-CR4 from transient voltage spikes.

**VOLTAGE REGULATION CIRCUIT**

Built into circuit card assembly PC101 (A1).

Controls firing time of silicon controlled rectifier SCR1 (Q1).

Keeps dc voltage at adjusted setting.

**EXPLANATION:**

- SCR1 (Q1) fires twice each cycle of ac input voltage. By controlling firing time, SCR1 (Q1) can be varied from full on when fired at start of each half-cycle to full off when fired at end of half-cycle.
- Bridge rectifier's dc output voltage can thus be varied from maximum possible voltage to zero.

**OVERVOLTAGE CIRCUIT****CIRCUIT PARTS:**

- Silicon controlled rectifier SCR2 (Q2).
- Low-resistance resistor R3.

Protects equipment being powered from overvoltages.

Activated when malfunction causes rise in output voltage.

**ACTION:**

- Circuitry in PC101 (A1) senses trouble, fires SCR2 (Q2).

**RESULTS:**

- Firing applies short-circuit load to output terminals which reduces output voltage to very low value.
- Short-circuit load opens circuit breaker CB1, which turns power supply OFF.
- This prevents possible damage to power supply and equipment being powered.

**VOLTAGE ADJUST CIRCUIT (DC OUTPUT)****CIRCUIT PARTS:**

- Variable dc voltage adjust resistors R4, R8.
- Stabilizing capacitor C3.
- Fixed resistor R11.

**CONNECTION:**

- Do output voltage fed through resistors to PC101(A1).

**VOLTAGE PATH:**

- Do output negative (-) terminal to PC101 (A1).
- Adjusts power supply's dc output voltage.
- Activated when dc output voltage changes.

ACTION:

- Manually adjust dc voltage adjust R4.
- Resistors R4, R8 change setting.
- Control circuitry in PC101(A1) senses change.

RESULTS:

- Output voltage changes proportionally.

RESISTOR FUNCTIONS:

- R4 adjusts output voltage.
- R8 adjusts voltage range.

**1-12. CONTROL CIRCUITS**

CIRCUIT CARD ASSEMBLY PC101(A1):

- Controls power supply operation.
- Senses voltage changes in ac input, dc output circuits.
- Controls operation of voltage regulation, overvoltage circuits.
- Derives power from two secondary windings on transformer T1.

**VOLTAGE REGULATION CONTROL**

PC101(A1) CONNECTS TO:

- Silicon controlled rectifier SCR1(Q1).
- Power supply's final dc output voltage.

**NOTE**

SCR1(Q1) regulates dc output voltage.

ACTION:

- PC101 (A1) applies signal to SCR1 (Q1) gate.
- SCR1(Q1) fires, conducts current after receiving signal.
- Timing of control gate signal appears on gate.

TIMING:

- Timing of control gate signal depends on value of output voltage fed to PC101(A1).

IF: Do output voltage increases

THEN: Time constants in PC101(A1) delay firing SCR1(Q1)

SO: SCR1(Q1) fires later in half-cycle

WHICH: Reduces output voltage

This restores output voltage to proper value.

IF: Do output voltage decreases

THEN: SCR1(Q1) fires early

WHICH: Raises voltage to proper value.

**First Power Supply to PC101(A1)**

POWER:

- Plus and minus 20 volts.

## SOURCE:

- Center-tapped secondary winding, transformer T1.

## RECTIFIER BRIDGE CIRCUIT:

- PP-4763 Rectifier bridge Z 102.
- PP-4763A Individual diodes CR18, CR19, CR20, CR21.

## DC OUTPUT Z108 (CR18-CR21):

## FILTER:

- Resistor-capacitor filter circuit R102(R2); C103(C3); R103(R3); C104(C4).

## REGULATOR:

- Resistor R105(R5)
- Zener diodes CR109(CR9); CR110(CR10).

## PLUS-MINUS 20-VOLT SUPPLY CIRCUIT:

- Common point connects to power supply's positive output.

## PLUS 20-VOLT CIRCUIT:

- Supplies reference diode CR104(CR4) through resistor R113(R13).
- Output of CR104(CR4) provides bias current to base of transistor Q103(Q3).

## MINUS 20-VOLT CIRCUIT:

- Supplies voltage divider R107(R7), R115(R15), transmitter-resistor circuit Q103(Q3), R117(R17).

**Second Power Supply to PC101(A1)**

## SOURCE:

- Transformer T1, windings TB1-11, TB1-10.
- Current passes through current-limiting resistors R6, R7.

## RECTIFIER BRIDGE CIRCUIT:

- PP-4763 - Rectifier bridge Z101.
- PP-4763A - Diodes CR14, CR15, CR16, CR17.

## PULSATING DC OUTPUT, Z101 (CR14-CR17):

- Clipped by Zener diode CR109(CR9) through blocking diode CR105(CR5).
- Circuit output supplies:
  - Resistor-unijunction transistor circuit R108(R8), R109(R9), Q101(Q1).
  - Resistor-transistor circuit R111(R11), R112(R12), Q102(Q2).

## POWER SUPPLY'S OUTPUT VOLTAGE:

- Applied through front panel mounted adjustment assembly A4A2A1R11, A4A2R4 and A4A2R8, through resistor R120(R20), to base of transistor Q103(Q3).
- Base current Q103(Q3) creates current through R117(R17).
- Current creates bias voltage for base of Q102(Q2).
- This creates current flow through resistors R111(R11), R112(R12).
- This supplies capacitor C105(C5).
- C105(C5) connects through blocking diode CR112(CR12) to emitter of unijunction transistor Q101(Q1).

### Functional Description of PC101(A1) Power Supply Circuits

- Voltage of all secondary windings in transformer T1 becomes zero at same instant. At this instant:
- Anode-to-cathode voltage of controlled rectifier SC R1(Q1) also becomes zero and shuts OFF.
- As anode-to-cathode voltage rises, SC R1(Q1) stays OFF until PC101(A1) supplies signal to gate.
- Clipped pulsating voltage to unijunction transistor Q101(Q1) also becomes zero at this instant.
- Voltage to voltage divider R108, R109(R8, R9) builds to maximum value in approximately 0.3 millisecond.
- Voltage to base 2-base 1 circuit of Q101(Q1) builds to maximum value in 0.3 millisecond.
- Voltage to emitter Q101(Q1) builds slowly, due to charging time of capacitor C105(C5).
- Emitter-base 1 resistance decreases, which connects C105(C5) to:  
resistor R109(R9),  
gate of controlled rectifier SCR101(Q6).
- SC R101(Q6) turns on.
- Connects output of rectifier bridge Z102(CR18 through CR21) to gate of SCR1(Q1).
- SC R1(Q1) turns on.

### Results of Voltage Changes

- Action described above occurs twice per cycle (120 times/second with 60 Hz input).
- SC R1(Q1) is fired at same instant of each cycle.

IF: Output voltage changes (due to change in ac input voltage or dc output voltage).

THEN: Base current of transistor Q103(Q3) changes.

WHICH: Changes current through R117(R17).

WHICH: Changes base voltage of transistor Q102(Q2).

IF: Output voltage increases.

THEN: Base voltage of Q102(Q2) increases.

WHICH: Increases current through R111(R11).

WHICH: Reduces charging current into capacitor C105(C5).

WHICH: Delays firing time of unijunction transistor Q101(Q1).

WHICH: Delays firing of SCR1(Q1).

IF: SCR1(Q1) fires later in each half-cycle.

THEN: Output voltage reduced.

WHICH: Restores output voltage to proper value.

### OVERVOLTAGE CONTROL

#### OVERVOLTAGE CIRCUIT:

- Components: Silicon controlled rectifier SCR2 (Q2).
- Connected in series across dc output.

#### CONNECTIONS TO CONTROL CIRCUIT:

- Gate of SCR2 (Q2) connected to control circuit in PC101 (A1).
- Control circuit connected to positive (+), negative (-) dc output terminals.



SEQUENCE:

- Voltage rises above prescribed value.
- Signal applied to gate of SCR2 (Q2).
- SCR2 (Q2) conducts.
- Shorts output.
- Opens circuit breaker CB1.

**CONTROL CIRCUIT**

VOLTAGE DIVIDER:

- Resistors R121, R122, R123 (R21, R22, R23).
- Connected across dc output terminals.

REGULATOR DIODE CIRCUIT:

- Regulator diode CR106 (CR6).
- Resistor R124 (R24).
- Transistor Q104 (Q4).
- Supplies gate of silicon controlled rectifier SCR2 (Q2) through limiting resistor R125 (R25).

TRANSISTOR Q104 (Q4):

- Compares portion of output voltage with voltage of CR106 (CR6).

**NOTE**

Portion of voltage compared depends on setting of variable resistor R123 (R23).

IF: Output voltage rises above preset value.

THEN: Q104 (Q4) conducts.

WHICH: Fires SCR2 (Q2).

WHICH: Opens circuit breaker CB1.

CAPACITOR C108 (C8):

- Stabilizes operation.
- Insures against short time transients firing SCR2 (Q2).

CHAPTER 2

DIRECT SUPPORT MAINTENANCE

Section I. GENERAL INFORMATION

	PAGE
General .....	2-1
Repair Parts, Tools, Test Equipment, and Materials .....	2-1

Section II. TROUBLESHOOTING

Adjusting Voltage Control Circuits .....	2-20
Component Testing .....	2-14
Procedures .....	2-2
Symptom Index .....	2-3
Testing and Troubleshooting Circuit Card Assembly PC101(A1) .....	2-16
Troubleshooting Chart .....	2-4
Voltage and Resistance Data .....	2-18

Section III. MAINTENANCE PROCEDURES

Removing and Replacing Panels .....	2-22
Removing and Replacing Parts: .....	2-26
AC cable plug W3P1 .....	2-39
AC cable W3 .....	2-39
AC input links .....	2-26
Ammeter Ma .....	2-29
Capacitors C1, C2 .....	2-35
Circuit breaker CB1 .....	2-27
Circuit card assembly PC101(A1) .....	2-26
DC voltage adjust components R4, R8, R11, C3 .....	2-30
Diodes CR1-CR5 .....	2-32
Diode CR6 .....	2-42
Diode SCR1 (Q1) .....	2-37
Diode SCR2 (Q2) .....	2-38
Fanmotor BI .....	2-40
Interlock switch .....	2-43
Reactor L2 .....	2-34
Resistor R3 .....	2-37
Transformer T1 .....	2-41
Voltmeter M1 .....	2-28

Section IV. TEST PROCEDURES

Physical Tests and Inspections .....	2-44
Procedures .....	2-44
Static Voltage Regulation Test .....	2-45
Test Data Summary .....	2-48

**Section I. GENERAL INFORMATION**

**2-1. GENERAL**



Low voltage, high amperage current is present at output connections and connections inside equipment.

Shut off power supply before performing maintenance.

Be careful when working with 115 or 230-volt ac line connections.

Serious injury or death may result from contact with terminals.

This chapter covers direct support troubleshooting, maintenance, and testing procedures for the power supply. Section I lists the tools, test equipment, and materials needed to perform direct support maintenance. Troubleshooting procedures are described in Section II, maintenance procedures in Section III, and test procedures in Section IV.

**2-2. REPAIR PARTS, TOOLS, TEST EQUIPMENT, AND MATERIALS**

Repair Parts: Refer to TM 11-5820-765-34P-1.

Special Tools: No special tools are needed.

Tools, Test Equipment, and Materials:

ITEM	National Stock Number
<b>TOOLS</b>	
Tool Kit, Electronic Equipment TK-100/G	5180-00-605-0079
Tool Kit, Electronic Equipment TK-105/G	5180-00-610-8177
Torque Wrench, 150 inch-pounds	5120-00-230-6380
<b>TEST EQUIPMENT</b>	
Multimeter TS-352B/U	6625-00-553-0142
Transformer, Variable Power TF-171/USM	6120-00-503-0632
Voltmeter, Electronic AN/USM-98A	6625-00-753-2115
Voltmeter, Electronic ME-30(*)/U	6625-00-643-1670
<b>MATERIALS</b>	
Test Switch, Single-Pole (60-ampere)	
Resistor, 0.56 ohm, 1000 watts	
Resistor, 1.3 ohms, 1000 watts	5905-00-064-4679
Wire, Electrical, Stranded; No. 8 AWG	

## Section II. TROUBLESHOOTING

### 2-3. PROCEDURES

#### Definition

Troubleshooting is a two-step process -- localization and isolation.

Localization means tracing the fault to a defective circuit or assembly.

Isolation means pinpointing the specific part causing trouble.

#### Procedures

SENSE the trouble:

Check meter readings and other visual signs to localize trouble;

Check for dirt, dust, or moisture;

Smell for burned-out resistors and other parts;

Listen for arcing transformer or reactors;

Check for loose screws and nuts.

You can localize and isolate trouble this way and reduce repair time.

OPERATE the unit:

An operational test can often help isolate the exact cause of trouble.

USE the CHART:

The troubleshooting chart lists common symptoms, troubles and corrective measures.

Not all trouble symptoms are listed in the chart, so use it as a guide for analyzing symptoms not listed.

COMPONENT TESTING:

Paragraph 2-6.

Tests for defective diodes, meters, controlled rectifiers.

Use with troubleshooting chart.

Use to isolate defective part.

TESTING, TROUBLESHOOTING CIRCUIT CARD ASSEMBLY:

Paragraph 2-7.

VOLTAGE, RESISTANCE DATA:

Paragraph 2-8.

Voltage output, dc resistances for transformer, reactors.

ADJUSTING VOLTAGE CONTROL CIRCUITS:

Paragraph 2-9.

Adjustments after removing and replacing parts.

REMOVING AND REPLACING PARTS:

Paragraph 2-11.

**2-4. SYMPTOM INDEX**

Use index to quickly find procedures in troubleshooting chart.

Troubleshooting Symptom	Procedure Number	Page
POWER ON: VOLTMETER SHOWS ZERO VOLTAGE; FAN MOTOR B1 DOESN'T START.	1	2-5
POWER ON: VOLTMETER SHOWS LOW OR ZERO VOLTAGE; FAN DOESN'T START OR RUNS SLOW; CIRCUIT BREAKER MAY OR MAY NOT TRIP.	2	2-5
POWER ON: VOLTMETER SHOWS ZERO VOLTAGE; 27 VOLTS DC AT OUTPUT CONNECTIONS.	3	2-6
POWER ON: VOLTMETER MI SHOWS OUTPUT VOLTAGE; FAN MOTOR B1 DOESN'T START.	4	2-6
FAN MOTOR B1 OPERATES; VOLTMETER MI, AMMETER M2 REMAIN AT ZERO.	5	2-7
VOLTMETER MI INDICATES LOW VOLTAGE.	6	2-7
CIRCUIT BREAKER CB1 WON'T REMAIN ON.	7	2-8
POWER SUPPLY OPERATES AT EXCESSIVE HIGH VOLTAGE.	8	2-9
VOLTAGE FLUCTUATES DURING OPERATION.	9	2-10
OUTPUT VOLTAGE DOESN'T CHANGE WHEN DC VOLTAGE ADJUST CONTROL IS RESET MANUALLY.	10	2-11
VOLTMETER MI INDICATES POWER SUPPLY WORKING AT VOLTAGE BELOW OPERATING LIMITS.	11	2-12
AMMETER M2 SHOWS ABNORMAL CURRENT OR NO CURRENT DURING NORMAL OPERATION.	12	2-13
POWER SUPPLY HUMS LOUDLY DURING OPERATION.	13	2-13

2-5. TROUBLESHOOTING CHART

Troubleshooting chart is designed to supplement operational checks in TM 11-5820-765-12. Connect power supply to power source to conduct test procedures. Use repair procedure numbers shown in to locate repair procedures in Section III.

1 COLOR KEYED

2 ADDITIONAL INFORMATION

3 PROCEDURE STEPS

MALFUNCTION/SYMP TOM	PROBABLE CAUSE		
	TEST PROCEDURE	INDICATION	YES NO
<p><b>POWER ON: VOLTMETER SHOWS ZERO VOLTAGE; FAN MOTOR B1 DOESN'T START.</b></p> <p>① Visual check, ac cable plug W3P1 (PP-4763A).</p> <p>② Visual Check, ac cable W3.</p> <p>Preliminary: Remove top panel (para 2-10). Drop front panel.</p> <p>③ Connect multimeter across circuit breaker CB1 terminals; switch ON.</p>	<p><b>DEFECTIVE CIRCUIT BREAKER CB1. DEFECTIVE AC CABLE W3. DEFECTIVE AC CABLE PLUG W3P1.</b></p> <p>Connections secure, insulation and wiring sound, prongs not broken.</p> <p>Connections secure, insulation not worn, wiring not broken.</p> <p>Continuity.</p>	<p>Go to ② Replace (No. 14)</p> <p>Go to ③ Replace (No. 13)</p> <p>Replace (No. 3)</p>	
<p><b>POWER ON: VOLTMETER SHOWS LOW OR ZERO VOLTAGE; FAN DOESN'T START OR RUNS SLOW; CIRCUIT BREAKER MAY OR MAY NOT TRIP.</b></p> <p>PP-4763A CONNECTED TO 115 VAC SOURCE AC INPUT LINKS SET FOR 220-VOLT OPERATION.</p> <p><b>CAUTION</b></p> <p>For proper circuit breaker operation push handle halfway, until it engages, then flip up to set position.</p> <p>Preliminary: Remove top panel (para 2-10).</p> <p>① Set links Correctly (No. 1).</p>	<p>Power supply operates correctly.</p>	<p>Replace (No. 3)</p>	

1 Color coordinated MALFUNCTION/SYMP TOM to PROBABLE CAUSE zeroes in on the problem area.

2 WARNINGS, CAUTIONS and NOTES appear when applicable.

3 Flows logically, taking technician from most probable to least likely cause of malfunction.

4 Illustrated aids speed procedure and increase accuracy.

MALFUNCTION/SYMPOM	PROBABLE CAUSE		
TEST PROCEDURE	INDICATION	YES	NO
<p><b>POWER ON: VOLTMETER SHOWS ZERO VOLTAGE; FAN MOTOR B1 DOESN'T START.</b></p> <p>① Visual check, ac cable plug W3P1 (PP-4763A).</p> <p>② Visual check, ac cable W3.</p> <p>Preliminary:</p> <p>Remove top panel (para 2-10), Drop front panel.</p> <p>Do all continuity checks with power removed.</p> <p>③ Connect multimeter across circuit breaker CB1 terminals; switch ON.</p>	<p><b>DEFECTIVE CIRCUIT BREAKER CB1. DEFECTIVE AC CABLE W3. DEFECTIVE AC CABLE PLUG W3P1.</b></p> <p>Connections secure, insulation and wiring sound, prongs not broken.</p> <p>Connections secure, insulation not worn, wiring not broken.</p> <p>Continuity. ....</p>	<p>Go to ②</p> <p>Go to ③</p> <p>.....</p>	<p>Replace (No. 14)</p> <p>Replace (No. 13)</p> <p>Replace (No. 3)</p>
<p><b>POWER ON: VOLTMETER SHOWS LOW OR ZERO VOLTAGE; FAN DOESN'T START OR RUNS SLOW; CIRCUIT BREAKER MAY OR MAY NOT TRIP.</b></p> <p>Preliminary:</p> <p>Remove top panel (para 2-10).</p> <p>① Set links correctly (No. 1).</p>	<p><b>PP-4763A CONNECTED TO 115 VAC SOURCE, AC INPUT LINKS SET FOR 230 VOLT OPERATION.</b></p> <p>Power supply operates correctly. ....</p>	<p>.....</p>	<p>.....</p>

MALFUNCTION/SYMP TOM	PROBABLE CAUSE			
	TEST PROCEDURE	INDICATION	YES	NO
<p><b>POWER ON: VOLTMETER SHOWS ZERO VOLTAGE; 27 VOLTS DC AT OUTPUT CONNECTIONS.</b></p> <p>METER M1 DEFECTIVE.</p> <p>Preliminary: Remove top panel (para 2-10). Drop front panel.</p>				
<p>① Visual check, meter connections.</p>	Connections secure.	Go to ②	Repair defective connections	
<p>② Connect multimeter across meter M1.</p>	27 Vdc	Replace meter (No. 4)	-----	
<p><b>POWER ON: VOLTMETER M1 SHOWS OUTPUT VOLTAGE, FAN MOTOR B1 DOESN'T START.</b></p> <p>DEFECTIVE FAN MOTOR B1.</p> <p>Preliminary: Remove top panel (para 2-10). Drop front panel.</p>				
<p>① Visual check.</p>	Plug connected, blades not obstructed, wire connected to terminal.	-----	Replace (No. 15)	

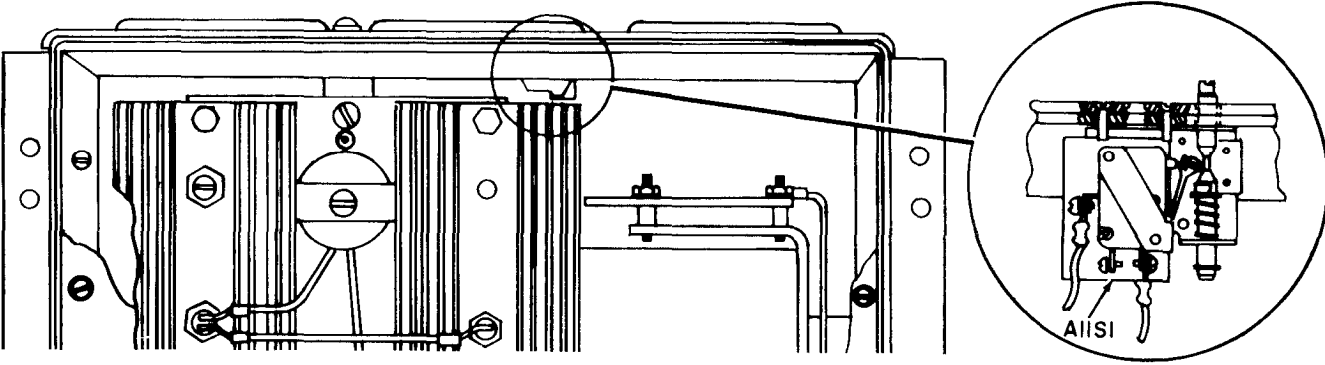

MALFUNCTION/SYMP TOM	PROBABLE CAUSE		
	TEST PROCEDURE	INDICATION	YES NO
<p><b>FAN MOTOR B1 OPERATES; VOLT-METER M1, AMMETER M2 REMAIN AT ZERO.</b></p> <p>Preliminary: Remove top panel (para 2-10). Drop front panel.</p> <p>① Measure dc resistance; connect multi-meter across terminals listed in paragraph 2-8.</p> <p>② Measure voltage output multimeter across terminals listed in paragraph 2-8.</p>	<p>OPEN PRIMARY WINDING, POWER TRANSFORMER T1. OPEN SECONDARY WINDING T1.</p> <p>Refer to dc resistance table (para 2-8).</p> <p>Refer to voltage output table (para 2-8).</p>	<p>Go to ②</p> <p>.....</p> <p>.....</p>	<p>.....</p> <p>.....</p> <p>Replace (No. 16)</p>
<p><b>VOLTMETER M1 INDICATES LOW VOLTAGE.</b></p> <p>Preliminary: Remove top panel (para 2-10). Drop front panel. Disconnect leads on CR1, CR4.</p> <p>① Connect multimeter leads to opposite ends of diode; measure internal resistance, both directions (para 2-6).</p> <p>② Measure dc resistance; connect multi-meter across TB4-2, CR4 (para 2-8).</p>	<p>DEFECTIVE FULL WAVE BRIDGE RECTIFIER DIODES CR1, CR2, CR3, CR4 OPEN WINDING, REACTOR L2.</p> <p>Forward resistance less than 5,000 ohms; reverse resistance more than 5000 ohms.</p> <p>0.001 ohm</p>	<p>Go to ②</p> <p>.....</p>	<p>Replace defective diode (No. 7)</p> <p>.....</p> <p>Replace (No. 8)</p>

MALFUNCTION/SYMPTOM	PROBABLE CAUSE			
	TEST PROCEDURE	INDICATION	YES	NO
<p><b>CIRCUIT BREAKER CB1 WON'T REMAIN ON.</b></p> 	<p><b>DEFECTIVE INTERLOCK SWITCH (A MODEL ONLY)</b></p> <p>PP-4763A CONNECTED TO 230-VOLT SOURCE; AC INPUT LINKS SET FOR 115-VOLT OPERATION.</p> <p><b>DEFECTIVE FULL-WAVE BRIDGE RECTIFIER DIODES CR1, CR2, CR3, CR4.</b></p> <p><b>SHORTED VOLTAGE SURGE PROTECTOR DIODE CR6.</b></p> <p><b>SHORTED FILTER CAPACITORS C1, C2.</b></p> <p><b>SHORTED POWER TRANSFORMER T1.</b></p>			
		<p>Preliminary:</p> <p>Remove top panel (para 2-10).</p> <p>① Continuity Check: Interlock switch.</p> <p>Position 1 . . . . . 2.2KΩ</p> <p>Position 2 . . . . . 0Ω</p> <p>Position 3 . . . . . 2.2KΩ</p>	<p>Continuity in order.</p>	<p>Go to ②</p>
	<p>② Visual check, ac input links.</p>	<p>Links set correctly.</p>	<p>Go to ③</p>	<p>Set links (No. 11)</p>

MALFUNCTION/SYMP TOM	PROBABLE CAUSE		
	TEST PROCEDURE	INDICATION	YES
<p>Preliminary: Remove front panel (para 2-10). Disconnect leads on CR1, CR4.</p> <p>③ Connect multimeter leads to opposite ends of diode; measure internal resistance, both directions (para 2-6).</p> <p>Preliminary: Disconnect wires on TB-4 No. 1.</p>	<p>Forward resistance less than 5000 ohms; Reverse resistance more than 5000 ohms.</p>	<p>Reconnect leads; Go to ④</p>	<p>Replace defective diode (No. 7)</p>
<p>④ Connect multimeter leads to opposite ends of diode; measure internal resistance, both directions (para 2-6).</p>	<p>Forward resistance less than 5000 ohms; Reverse resistance more than 5000 ohms.</p>	<p>Reconnect leads, Go to ⑤</p>	<p>Replace defective diode (No. 17)</p>
<p>⑤ Connect multimeter across (+) and (-) terminal connections; measure resistance of capacitors C1 and C2.</p>	<p>Meter reading goes to 0Ω then rises slowly.</p>	<p>Go to ⑥</p>	<p>Replace (No. 9)</p>
<p><b>NOTE</b></p> <p>If reading remains zero, visually check for shorts across busses. If there are none, then disconnect bus bar and determine which capacitor is defective. Defective capacitors are determined by resistance readings.</p>			
<p>⑥ Connect multimeter across terminals listed in paragraph 2-8; measure voltage output and dc resistance.</p> <p><b>POWER SUPPLY OPERATES AT EXCESSIVE HIGH VOLTAGE.</b></p>	<p>Refer to tables (para 2-8).</p> <p>DEFECTIVE CIRCUIT CARD ASSEMBLY PC101 (A1).</p> <p>DEFECTIVE SILICON CONTROLLED RECTIFIER SCR2 (Q2).</p> <p>DEFECTIVE RESISTOR R3.</p> <p>DEFECTIVE SECONDARY CONTROL WINDING, POWER TRANSFORMER T1.</p>	<p>.....</p>	<p>Replace (No. 16)</p>
<p>① Follow procedures in paragraph 2-7.</p>	<p>Refer to tables (para 2-7).</p>	<p>Go to ②</p>	<p>Replace (No. 2)</p>
<p><b>NOTE</b></p> <p>Refer to FO-2, FO-3.</p>			

MALFUNCTION/SYMPOM	PROBABLE CAUSE		
	TEST PROCEDURE	INDICATION	YES
Use care in disconnecting leads on rectifier.			
<p>② Connect multimeter to opposite sides of SCR2(Q2) rectifier; measure internal resistance in both directions.</p> <p>Reverse leads; measure gate-cathode resistance (para 2-6).</p>	<p>Meter reading goes to 0 Ω then rises slowly.</p>	<p>.....</p> <p>Go to ③</p>	<p>.....</p> <p>Replace (No. 12)</p>
<p>③ Disconnect one end of resistor, connect multimeter to opposite ends of resistor; measure resistance. (Take care removing hardware.)</p>	<p>0 ohm</p>	<p>Go to ④</p>	<p>Replace (No. 10)</p>
<p>④ Connect multimeter across terminals listed in paragraph 2-8; measure voltage output and dc resistance.</p>	<p>Refer to tables (para 2-8).</p>	<p>.....</p>	<p>Replace (No. 16)</p>
<p><b>VOLTAGE FLUCTUATES DURING OPERATION.</b></p>	<p><b>DEFECTIVE CIRCUIT CARD ASSEMBLY PC101(A1).</b></p> <p><b>DEFECTIVE DIODE CR5.</b></p> <p><b>DEFECTIVE SILICON CONTROLLED RECTIFIER SCR1 (Q1).</b></p> <p><b>DEFECTIVE REACTOR L2.</b></p> <p><b>DEFECTIVE VOLTMETER M1.</b></p> <p><b>DEFECTIVE SECONDARY CONTROL WINDING, POWER TRANSFORMER T1.</b></p>		
<p>① Follow procedures in paragraph 2-7.</p> <p>Disconnect leads on CR5.</p>	<p>Refer to tables (para 2-7).</p>	<p>Go to ②</p>	<p>Replace (No. 2)</p>
<p>② Connect multimeter leads to opposite ends of diode; measure internal resistance, both directions.</p>	<p>Forward resistance less than 5000 ohms; reverse resistance more than 50,000 ohms.</p>	<p>Go to ③</p>	<p>Replace (No. 7)</p>

MALFUNCTION/SYMPTOM	PROBABLE CAUSE			
	TEST PROCEDURE	INDICATION	YES	NO
<p>Disconnect lead on Q1.</p> <p>③ Connect multimeter leads to opposite ends of rectifier; measure anode-cathode resistance.</p>	<p>Lower than 1 megohm in one direction; 0 ohms in one direction.</p>	<p>Continue test; Go to ④</p>	<p>Continue test</p>	
<p>Reverse leads; measure gate-cathode resistance.</p>	<p>1000 ohms</p>	<p>.....</p>		<p>Replace (No. 11)</p>
<p>④ Connect multimeter across TB4-2 and cathode at CR4; measure dc resistance (para 2-8).</p>	<p>0 ohm</p>	<p>Go to ⑤</p>		<p>Replace (No. 8)</p>
<p>⑤ Disconnect one end of meter (M1). Connect multimeter across meter terminals; measure resistance (para 2-6).</p>	<p>50,000 ohms</p>	<p>Go to ⑥</p>		<p>Replace (No. 4)</p>
<p>⑥ Connect multimeter across terminals listed in para. 2-8; measure voltage output dc resistance.</p>	<p>Refer to tables (para 2-8).</p>	<p>.....</p>		<p>Replace (No. 16)</p>
<p><b>OUTPUT VOLTAGE DOESN'T CHANGE WHEN DC VOLTAGE ADJUST CONTROL IS RESET MANUALLY.</b></p>	<p><b>DEFECTIVE CIRCUIT CARD ASSEMBLY PC101 (A1).</b></p> <p><b>SHORTED VARIABLE RESISTOR R4.</b></p> <p><b>DEFECTIVE VARIABLE RESISTOR R8.</b></p> <p><b>DEFECTIVE RESISTOR R11.</b></p> <p><b>DEFECTIVE SECONDARY CONTROL WINDING, POWER TRANSFORMER T1.</b></p>			
<p>① Follow procedures in paragraph 2-7.</p>	<p>Refer to tables (para 2-7).</p>	<p>Go to ②</p>		<p>Replace (No. 2)</p>
<p>② Disconnect one end of resistor R4, connect multimeter to opposite ends of resistor; measure resistance.</p>	<p>5000 ohms</p>	<p>Go to ③</p>		<p>Replace (No. 6)</p>
<p>③ Disconnect one end of resistor R8, connect multimeter to opposite ends of resistor; measure resistance.</p>	<p>10,000 ohms</p>	<p>Go to ④</p>		<p>Replace (No. 6)</p>

MALFUNCTION/SYMPTOM	PROBABLE CAUSE		
	TEST PROCEDURE	INDICATION	YES
<p>④ Disconnect one end of resistor R11, connect multimeter to opposite ends of resistor; measure resistance.</p>	2700 ohms	Go to ⑤	Replace (No. 6)
<p>⑤ Connect multimeter across terminals listed in paragraph 2-8; measure voltage output and dc resistance.</p>	Refer to tables (para 2-8).	.....	Replace (No. 16)
<p><b>VOLTMETER M1 INDICATES POWER SUPPLY WORKING AT VOLTAGE BELOW OPERATING LIMITS.</b></p>	<p><b>PP-4763A CONNECTED TO 230-VOLT SOURCE; AC INPUT LINKS SET FOR 115-VOLT OPERATION.</b></p> <p><b>DEFECTIVE CIRCUIT CARD ASSEMBLY PC101 (A1).</b></p> <p><b>DEFECTIVE RESISTOR R11.</b></p> <p><b>DEFECTIVE VOLTMETER M1.</b></p> <p><b>SHORTED WINDING, POWER TRANSFORMER T1.</b></p>		
<p>① Follow procedures in paragraph 2-7.</p>	Refer to tables (para 2-7).	Go to ②	Replace (No. 2)
<p>② Disconnect one end of resistor, connect multimeter to opposite ends of resistor; measure resistance.</p>	2700 ohms	Go to ③	Replace (No. 6)
<p>③ Connect multimeter across meter terminals; measure resistance (para 2-6).</p>	50,000 ohms	Go to ④	Replace (No. 4)
<p>④ Connect multimeter across terminals listed in paragraph 2-8; measure voltage output and dc resistance.</p>	Refer to tables (para 2-8).	.....	Replace (No. 16)

MALFUNCTION/SYMP TOM	PROBABLE CAUSE		
TEST PROCEDURE	INDICATION	YES	NO
<p><b>AMMETER M2 SHOWS ABNORMAL CURRENT OR NO CURRENT DURING NORMAL OPERATION.</b></p> <p>① Disconnect one ammeter lead. Connect multimeter across ammeter terminals; measure current.</p>	<p>DEFECTIVE AMMETER M2.</p> <p>23 amperes at 115-volt operation; 11.5 amperes at 230-volt operation (PP-4763A).</p>		<p>Replace (No. 5)</p>
<p><b>POWER SUPPLY HUMS LOUDLY DURING OPERATION.</b></p> <p>① Carefully force wedges back in place with rubber mallet.</p>	<p>LOOSE WEDGES, POWER TRANSFORMER T1, REACTOR L1.</p> <p>Wedges tight, no hum.</p>	<p>.....</p>	<p>.....</p>

## 2-6. COMPONENT TESTING

The following voltage and resistance measurements show if diodes, meters, and controlled rectifiers are defective

CAPACITORS CARRY A CHARGE AFTER POWER SUPPLY IS SHUT OFF  
BEFORE PERFORMING TESTS:  
SHUT OFF POWER SUPPLY.  
DISCONNECT FROM AC POWER SOURCE.  
DISCHARGE CAPACITORS BY SHORTING OUT WITH SHORTING ROD.

### Diodes

Test equipment: Multimeter TS-352B/U

Measure: Internal resistance, both directions.

Multimeter select switch: RX1

Procedure:

Remove panel(s).

Disconnect diode being tested by removing screws and leads.

Connect multimeter leads to ends of diode; take reading.

Reverse leads on diode; take reading.

Diode defective if reading shows:

Forward resistance more than 5000 ohms.

Reverse resistance less than 500 ohms.

0 ohms, both directions.

Reconnect diodes. Replace panel(s).

### Meter M1

Function:

50-volt, 1000-ohm-per-volt meter.

Test equipment:

Multimeter TS-352B/U

Voltmeter AN/USM-98A

Procedure:

Open front panel for both tests.



Defect test:

Set multimeter to RX1000.  
Connect leads across meter terminals; take reading.  
Multimeter should read 50,000 ohm resistance across terminals.  
Different reading indicates defect.

Accuracy test:

Set multimeter to RX1.  
Parallel-connect Voltmeter AN/USM-98A across meter's terminals.  
Check zero-adjust - move zero-adjust screw in both directions.  
Needle on MI scale should be moveable above and below zero line.

**Meter M2**

Function: 50-millivolt meter

Test equipment: Voltmeter AN/USM-98A

Accuracy test:

Parallel-connect voltmeter across meter terminals.  
Check zero-adjust movement.  
Needle on M2 scale should be moveable above and below zero line.

**Controlled Rectifiers**

Test equipment: Multimeter TS-352B/U

Measure: Internal resistance

Set multimeter to RX1.

Procedure:

Remove panel(s).  
Disconnect gate and cathode leads of rectifier being tested.

Tests:

Anode-cathode resistance:

Connect multimeter leads to opposite sides of rectifier.  
Rectifier defective if reading shows: 0 ohms in both directions.  
1 megohm or higher in both directions.

Gate-cathode resistance:

Reverse leads.  
Rectifier defective if reading shows 5000 ohms or higher (Indicates open circuit).

**NOTE**

Reading for gate-cathode resistance should be approximately 1000 ohms  
(low resistance scale on ohmmeter).

Reconnect rectifier leads.

2-7. TESTING AND TROUBLESHOOTING CIRCUIT CARD ASSEMBLY PC101 (A1)



**CAPACITORS CARRY A CHARGE AFTER POWER SUPPLY IS SHUT OFF.**

**BEFORE PERFORMING TESTS:**

**SHUT OFF POWER SUPPLY.**

**DISCONNECT FROM AC POWER SOURCE.**

**DISCHARGE CAPACITORS BY SHORTING OUT WITH SHORTING ROD.**

**General Instructions**

Test equipment: Multimeter TS-352B/U

Remove top panel (para 2-10).

Make visual check for overheated components or circuits. If there is visual evidence, check suspected circuit card component with multi meter.

If there is no evidence of overheating, remove PC101 (A1) from power supply (para 2-11). Make resistance checks on following page with multi meter.

**NOTE**

Measure both forward and reverse conductivity. Set test meter select switch at RX 1000.

**Checking PC101**

Measure: Resistance of assembly components.

Connection: Location of connector terminals PC101:

(bottom view)

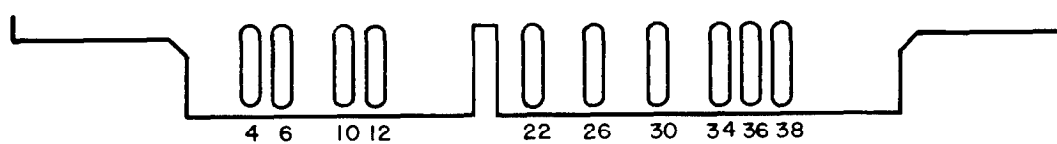

<b>Test procedure: PC101J101 Between Terminals</b>	<b>Forward Resistance</b>	<b>Reverse Resistance</b>
12-30	10K	High (greater than 20K)
12-26	10K	High (greater than 20K)
4-6	1K - 4K	1K - 4K
12-34	11K	Infinity
26-30	45K	45K
6-12	Zero	Zero
6-36	High (greater than 10K)	High (greater than 10K)
6-38	High (greater than 10K)	High (greater than 10K)
10-22	High (greater than 10K)	High (greater than 10K)
10-12	14K	200K

**Checking A1 (PP-4763A)**

Measure: Resistance of assembly components.

Test points: A1TP1 through A1TP6.

Connections: Location of test points:

(bottom view)

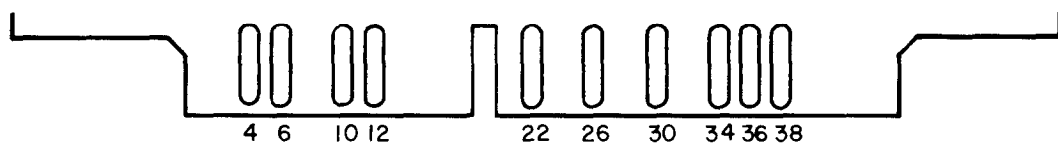

Make same resistance measurements as above. (Refer to fig. 2, para 3-6.)

Make direct resistance measurements of A1 components, using these test points:

<b>A1 Test Points Between</b>	<b>A1J101 Terminals</b>	<b>Forward Resistance</b>	<b>Reverse Resistance</b>
A1TP3	34	400K	Infinity
A1TP2	12	0	14K
A1TP5	12	220Ω	1560Ω
A1TP1 to A1TP2	.....	50K	Infinity
A1TP6	12	0	100K
A1TP4	6	2.1K	2.5K

2-8. VOLTAGE AND RESISTANCE DATA

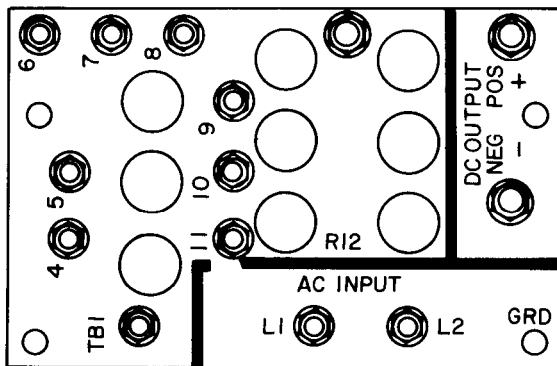

(FOR PP-4763/GRC)

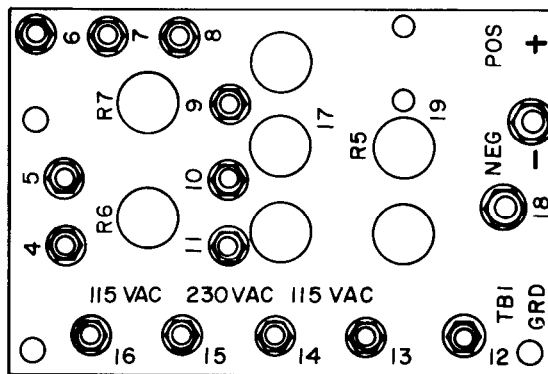

(FOR PP-4763A/GRC)

- Open front, remove top panel (para 2-10). Pull interlock switch up.

VOLTAGE OUTPUT, POWER TRANSFORMER T1

Voltage measurements, T1 secondary windings, normal operating conditions:

Between secondary winding terminals		AC voltage indication (approximate)	
		PP-4763	PP-4763A
TB4-1	TB4-2	50	52.0
TB1-11	TB1-10	115.0	115.0
TB1-6	TB1-7	32	33.4
TB1-6	TB1-8	64	66.7

DC RESISTANCE, TRANSFORMER and REACTORS

- Measure resistance with power OFF.
- Disconnect power plug, turn switch OFF before taking measurements.
- Remove top panel (para 2-10).
- Check transformer, reactors for defects before making resistance measurements.
- Use troubleshooting chart.

CAUTION

Normal resistance measurements may not detect some arcing and shorting that occurs during normal operation. Use sight, smell, and hearing to try to isolate defective part.

DC resistances:

Convert readings to zero or change test equipment

Transformer, reactors	Between terminals	Resistance (ohms) (*)
PP-4763 T1	TB1-3 TB1-12	0.06
	TB4-1 TB4-2	0.015
	TB1-11 TB1-10	2.6
	TB1-8 TB1-6	0.40
	TB1-8 TB1-7	0.40

NOTE

(\*) For all readings below 1 ohm, table should read less than 1 ohm.

Transformer, reactors	Between terminals		Convert readings to zero or change test equipment Resistance (ohms) (*)	
PP-4763A	Reactor L1	TB2-2	CR5 heatsink 0.015	
	Reactor L2	TB4-2	CR4 0.001	
	T1	TB1-12 TB1-14 TB4-1 TB1-11 TB1-8	TB1-15 TB1-16 TB4-2 TB1-10 TB1-6	0.12 0.12 0.015 2.6 0.4
	L1	TB2-2	CR5 heatsink 0.015	
	L2	TB4-2	CR4 0.001	
	Choke L3	CR2/CR3 junction	L3/R10 junction 1.9	

**NOTE**

(\*) For all readings below 1 ohm, table should read less than 1 ohm.

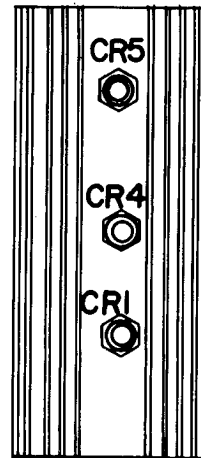
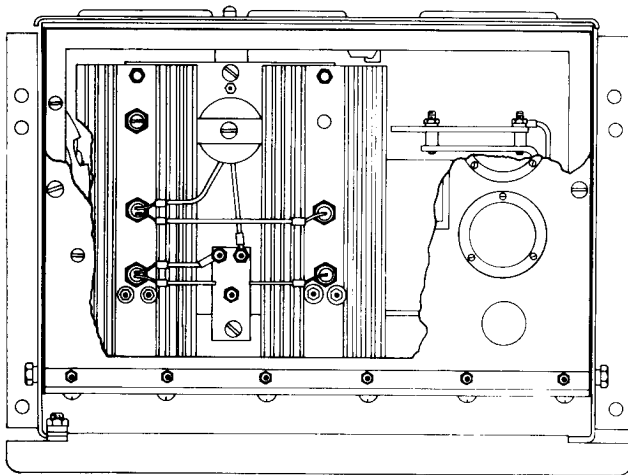

### 2-9. ADJUSTING VOLTAGE CONTROL CIRCUITS

After removing and replacing any parts, test power supply as outlined in Section IV, and make necessary adjustments to voltage control circuits.

#### CAUTION

Do not disturb factory settings unless tests indicate a need for readjustment.

Test equipment:

- Multimeter TS-352B/U
- Transformer TF-171/USM
- Voltmeter AN/URM-145

#### CAUTION

For PP-4763A, set ac input links to 115-volt operation before connecting power supply and test equipment to source.

#### Voltage Adjust Circuit

Connect power supply to 115-volt ac source and to test equipment as shown.

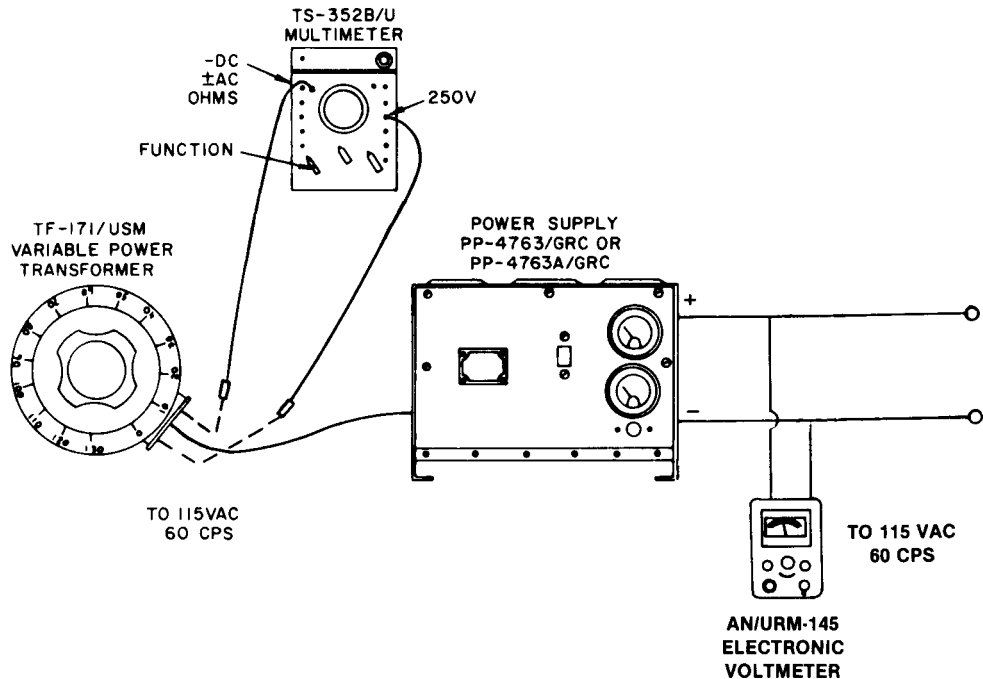

Procedure:

- Set transformer for 1 15-volt output.
- Remove dc voltage-adjust panel cover.
- Open front panel.
- Switch CB1: ON
- Set dc voltage-adjust control R4 fully clockwise.
- Loosen locknut on variable resistor R8.
- Adjust R8 until power supply voltage is 29 volts minimum, 30 volts maximum, (take reading on Voltmeter AN/URM-145).
- Tighten locknut.
- CB1: OFF
- Close front panel.

**Overvoltage Circuit**

- Remove rear panel (refer to para 2-10).
- Connect jumper lead across silicon Controlled Rectifier SCR1 (Q1) as shown. Use No. 8 (or larger) AWG wire.

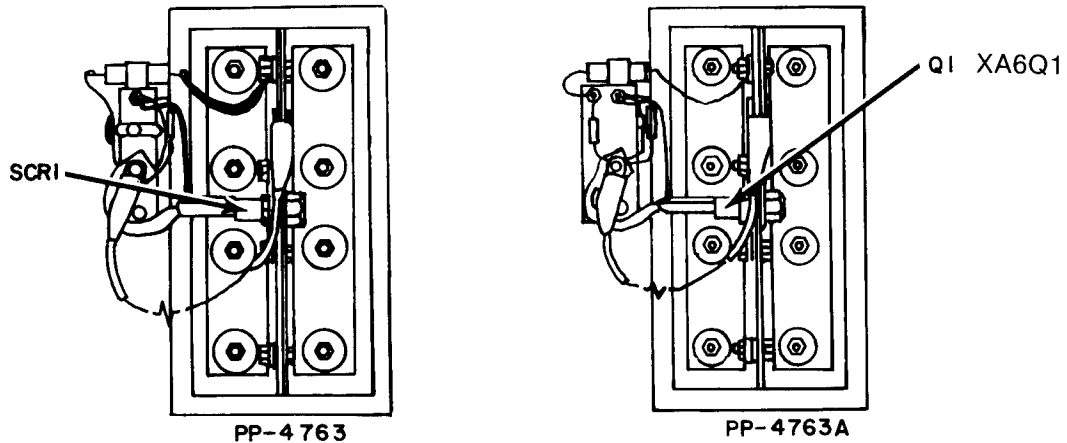

Set transformer to 115-volt output.

With no load connected across power supply's dc output:

Increase AC line voltage input to power supply until dc output reads 35 volts  $\pm 0.1$  volt (on Voltmeter ME-30(\*)/U), or until Controlled Rectifier SCR2(Q2) fires, tripping CB1.

If SCR2(Q2) does not fire:

Turn Variable Resistor PC101R123(A1R23) clockwise until SCR2(Q2) fires at 35 volts  $\pm 0.1$  volt. Refer to figure 1, figure 2, Chapter 3-6.

Seal adjustment screw on PC101R123(A1R23).

Remove all input power to supply.

Remove jumper leads from SCR1(Q1).

Replace rear panel.

Section III. MAINTENANCE PROCEDURES



Shut off power supply before performing maintenance.  
Capacitors carry a charge after power supply is shut off.  
Short out capacitors with shorting rod.

Be careful during removal and replacement.  
You can prevent accidental damage to other parts, and you can prevent potential short circuits caused by dropped hardware.  
When removing and replacing a part, check carefully for loose hardware or insecure electrical connections.  
Do not operate equipment until you make these checks.

**NOTE**

No special tools or procedures are needed to remove and replace power supply parts.

**2-10. REMOVING AND REPLACING PANELS.**

The power supply's front, top, and rear panels can be removed to allow maintenance inside the unit.

**NOTE**

For PP-4763A, you must remove the top panel to open the hinged front panel. Safety interlock switch S1 is spring-loaded.

**Top Panel**

- Remove 15 machine screws, washers, nuts.
- Disconnect fan plug.

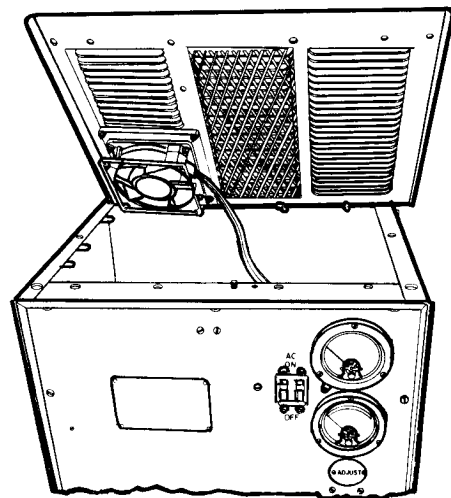
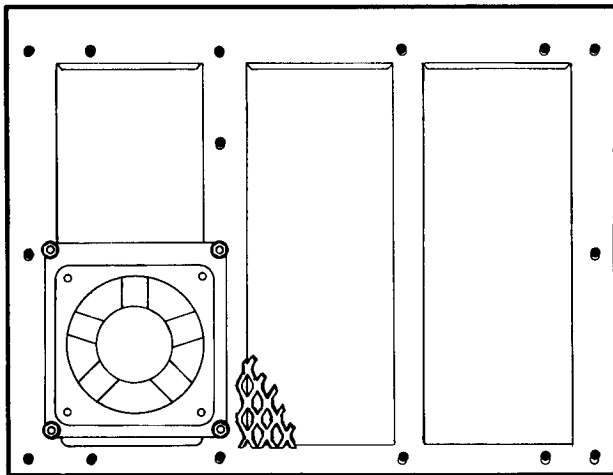

- To replace top panel, connect fan plug and replace 15 screws, washers, nuts.



**Front Panel**

- Remove five machine screws, washers, nuts.

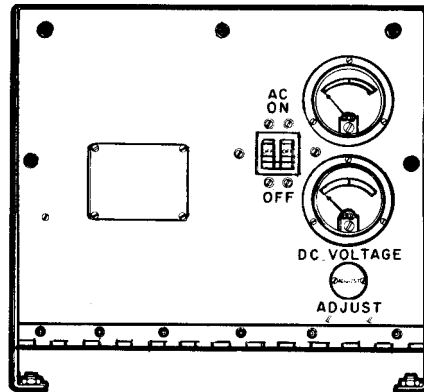

To replace front panel, replace screws, washers, nuts.

**Rear Panel**

**NOTE**

Two people are required for removal and replacement.

- Position power supply to provide access to the bottom.
- Remove four screws, washers, nuts on the bottom (rear side) of the power supply.
- Return power supply to upright position.

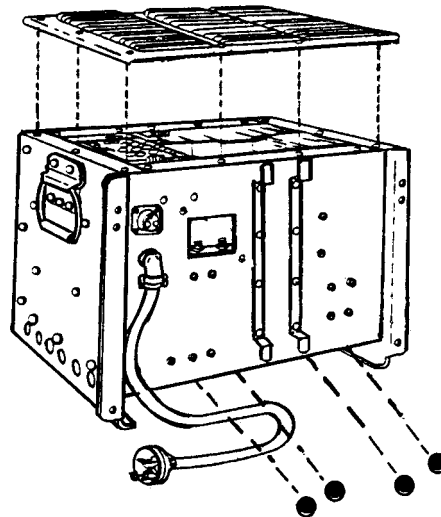

- Remove top panel.
- Remove six screws, washers, nuts from the side panels.

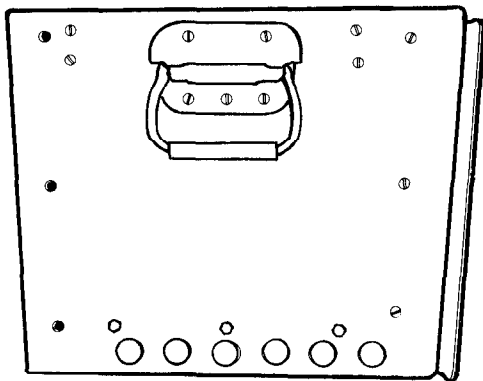

Left

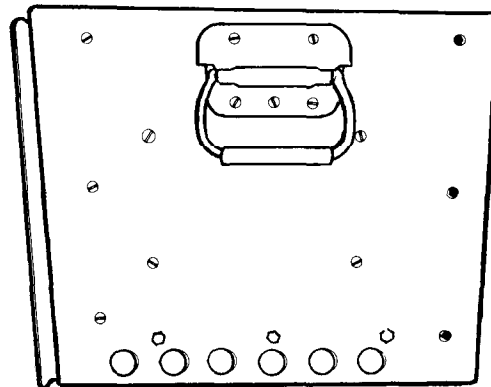

Right

- Carefully tilt rear panel outward.

- Tag and remove the following wires from the rear panel:

**PP-4763**

- W6 from SCR1.
- W8 and W134 from TB3.
- W56 from POS output terminal.
- W57 from NEG output terminal.
- W138 from TB2.
- L1 and L2 from TB1.
- POS and NEG from TB1.

**PP-4763A**

- W6 from Q1 (heats ink).
- W8 and W134 from TB3.
- W12 and W13 from TB2.
- W201 and W202 from FL1.
- POS and NEG from FL1.
- Remove rear panel.

- To replace rear panel, solder identified wires to proper terminals.
- Position rear panel.
- Replace six screws, washers, nuts on the side panels.
- Replace four screws, washers, nuts on the bottom of the power supply.

2-11. REMOVING AND REPLACING PARTS.



Maintenance procedures are numbered for easy access. Troubleshooting procedure numbers are given as a cross-reference.

1. AC INPUT LINKS (PP-4763A)

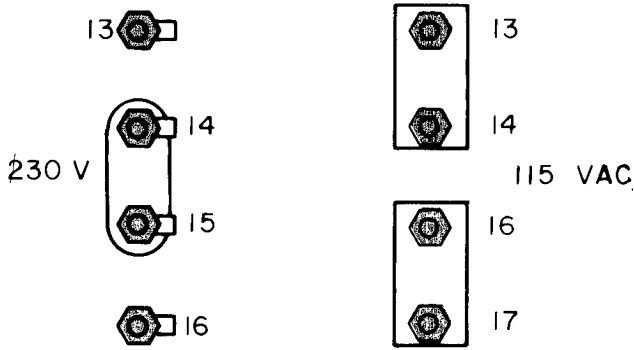

PP-4763A ONLY

- Carefully remove top panel (para 2-10).
- Loosen hexagon nuts on links.
- Move to correct terminal lugs.
- Tighten nuts.
- Replace panels.

2. CIRCUIT CARD ASSEMBLY PC101(A1)

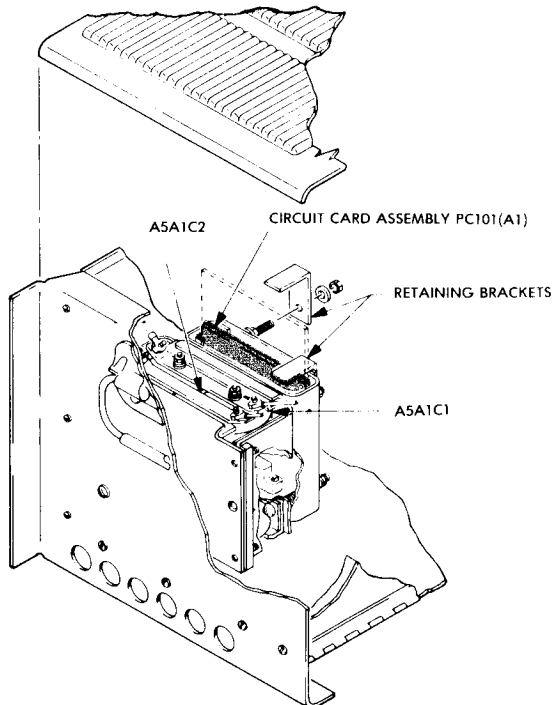
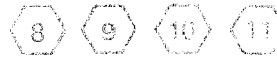

REMOVE

- Remove top panel (para 2-10).
- Remove retaining bracket nuts, washers.
- Remove retaining brackets.
- Lift circuit card assembly straight up from socket.

**CAUTION**

Be careful not to break solder connections when pulling the circuit card.

REPLACE

- Insert new circuit card assembly into socket. Be sure that circuit card terminal points are set all the way into the socket.
- Replace retaining brackets, nuts, washers.

3. CIRCUIT BREAKER CB1

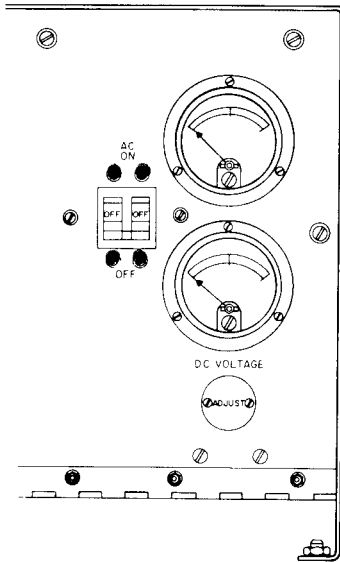

REMOVE

- Loosen two machine screws (four screws, PP-4763A).
- Open front panel.
- Remove screws, washers, nuts.
- Remove switch cover bracket.
- Remove switch cover.
- Disconnect leads from circuit breaker and tag.
- Remove circuit breaker.

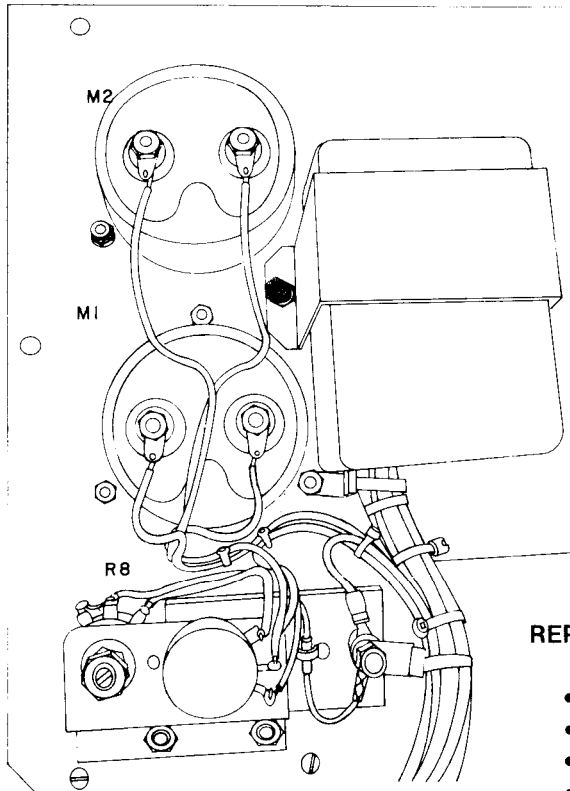

PP-4763A

CBI<sub>B</sub>      CBI<sub>A</sub>

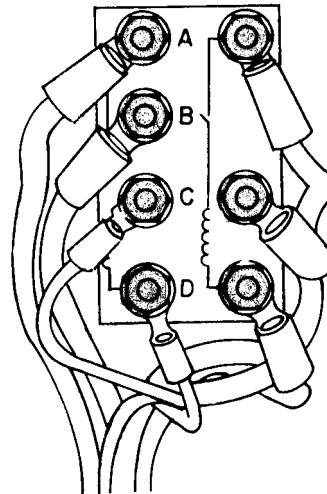

REPLACE

- Install new circuit breaker.
- Connect leads.
- Replace switch cover, switch cover bracket.
- Replace screws, washers, nuts.

4. VOLTMETER M1



**REMOVE**

Open front panel.  
 Remove three machine screws, washers, nuts.  
 Remove meter mounting gasket.  
 Loosen terminal lugs, disconnect leads (4763),  
 unsolder connections, and tag.  
 Remove meter.

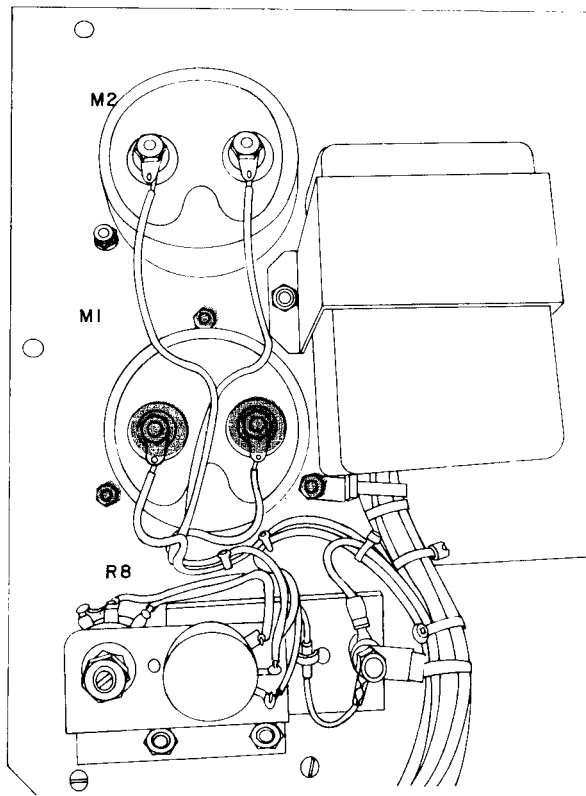
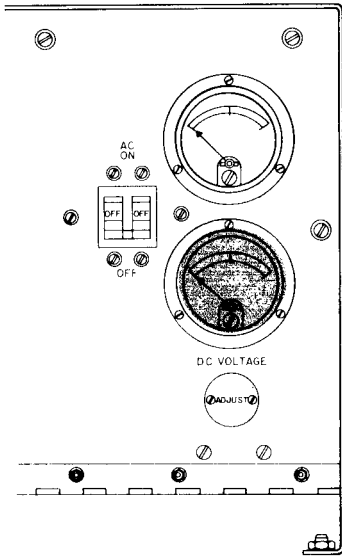

**REPLACE**

- Install new meter.
- Reconnect leads, tighten terminal lugs.
- Replace meter mounting gasket.
- Replace machine screws, washers, nuts.

## 5. AMMETER M2

### REMOVE

- Open front panel.
- Remove three machine screws, washers, nuts.
- Remove meter mounting gasket.
- Loosen terminal lugs, disconnect leads and tag.
- Remove meter.

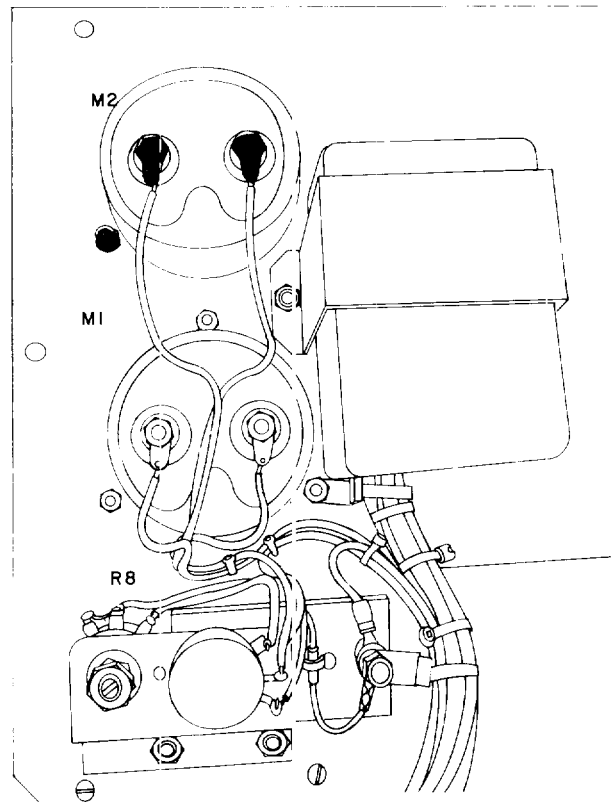
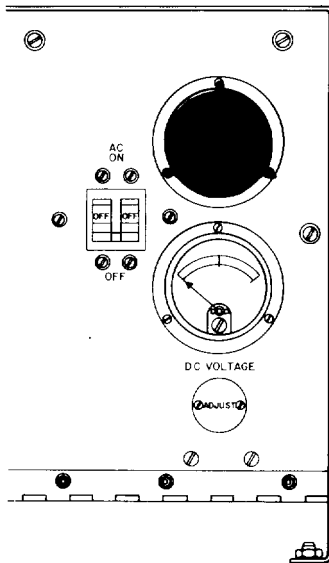

### REPLACE

- Install new meter.
- Replace leads, tighten terminal lugs.
- Replace meter mounting gasket.
- Replace machine screws, washers, nuts.

## 6. DC VOLTAGE ADJUST COMPONENTS

### RESISTOR R4

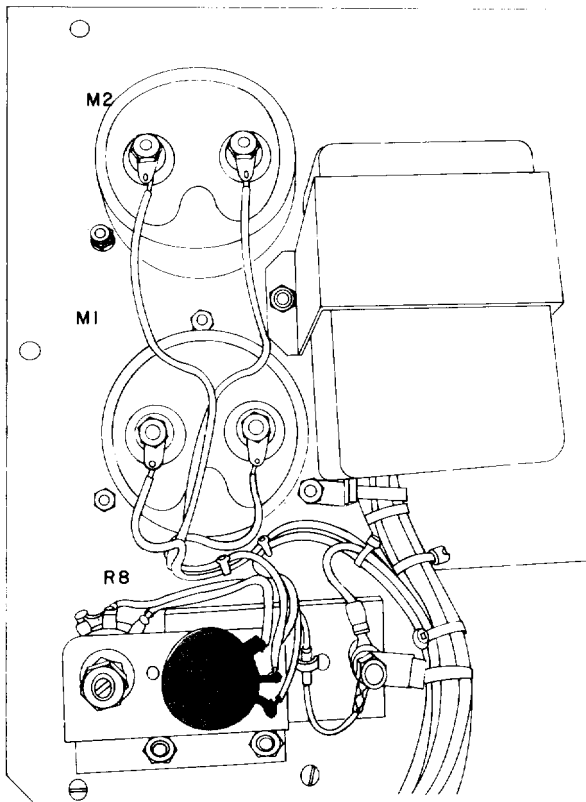

#### REMOVE

- Open front panel.
- Remove two outside screws, nuts, washers.
- Unsolder leads, and tag.
- Remove locknut, mounting nut, washer.
- Remove resistor.

#### REPLACE

- Put new resistor in place.
- Replace screw, nut, washer.
- Solder leads.
- Replace two outside screws, nuts, washers.

### RESISTOR R8

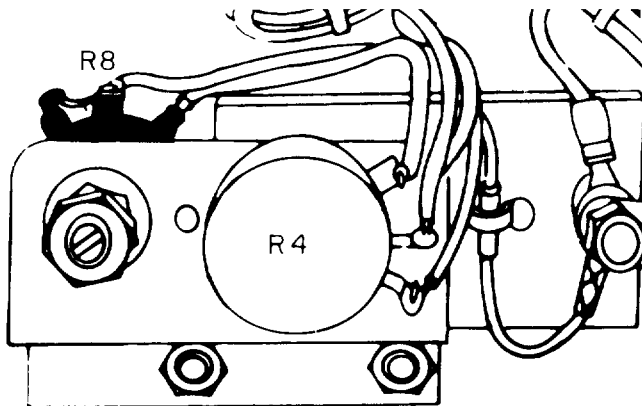

#### REMOVE

- Open front panel.
- Remove two outside screws, nuts, washers.
- Unsolder leads and tag.
- Remove locknut, mounting nut, washer.
- Remove resistor.

#### REPLACE

- Put new resistor in place.
- Replace screw, nut, washer.
- Solder leads.
- Replace two outside screws, nuts, washers.



RESISTOR R11

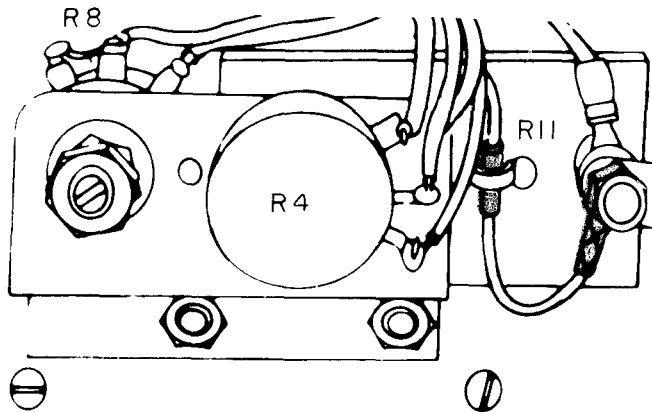

**REMOVE**

- Open front panel.
- Remove two outside screws, nuts, washers.
- Unsolder resistor lead.
- Remove nut, washer, wire wrap, nut, washers from terminal.
- Cut wire wrap around resistor.
- Remove resistor.

**REPLACE**

- Put resistor in place.
- Install new wire wrap around resistor.
- Replace nut, washer, wire wrap, nut, washer.
- Solder resistor lead.

CAPACITORS C3 (PP-4763)

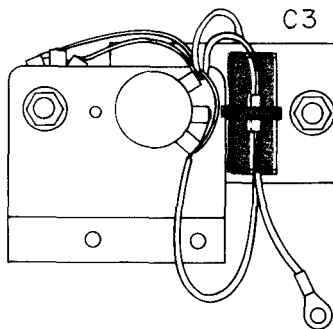

**REMOVE**

- Open front panel.
- Remove resistor R11 (follow steps above).
- Unsolder leads.
- Remove capacitor.

**REPLACE**

- Put new capacitor in place.
- Solder leads.
- Replace resistor R11 (follow steps above).

7. DIODES CR1, CR2, CR3, CR4, CR5



(CR1-CR4)



(CR5)

DIODES CR1, CR4, CR5

REMOVE

- Remove top panel (para 2-10)
- Open front panel.
- Remove and tag leads from right heatsink:  
W16 from CR3;  
W15 from CR2
- Remove right heatsink:  
Remove nuts, washers, spacers, and choke lead from 7/16" bolt at top of heatsink.  
Remove two nuts, washers, spacers at bottom of heatsink.
- Remove mounting nut on diode.

CAUTION

Use care in removing diodes. Observe polarity when removing and replacing diodes.

- Remove diode.

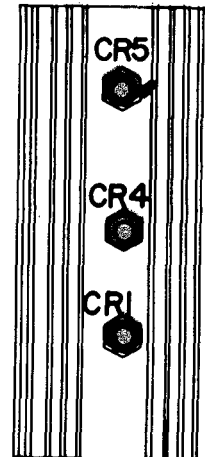
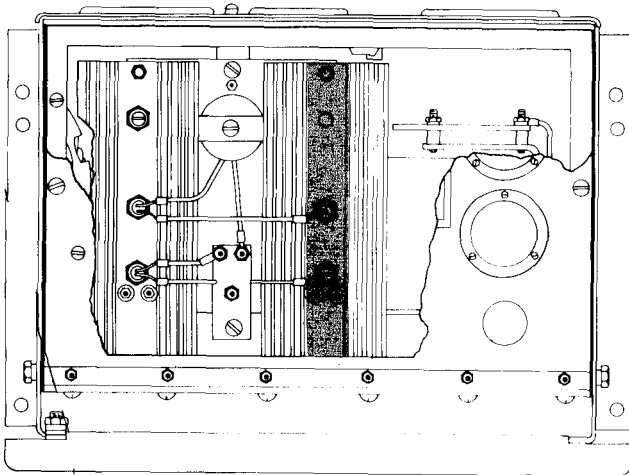

REPLACE

- Install new diode.
- Tighten mounting nut to 20 inch-pounds torque with torque wrench.
- Replace heatsink:  
Replace two nuts, washers, spacers at bottom.  
Replace lead nuts, washers, spacers at top.  
Replace lead at top of heatsink.
- Connect leads:  
W4 W15 to CR1;  
W16, L2 lead to CR4;  
W15 to CR5.

## DIODES CR2, CR3



## REMOVE

- Remove top panel (para 2-10)
- Open front panel.
- Remove and tag leads from right heatsink:
  - W16 from CR3;
  - W15 from CR2
- Remove right heatsink:
  - Remove nuts, washers, spacers, and choke lead from 7/16" bolt at top of heatsink.
  - Remove two nuts, washers, spacers at bottom of heatsink.
- Remove mounting nut on diode.

## CAUTION

Use care in removing diodes. Observe polarity when removing and replacing diodes.

- Remove diode.

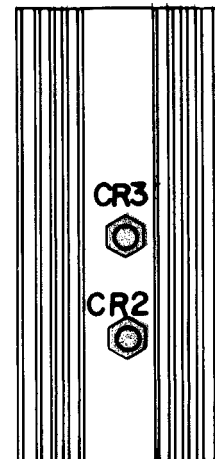
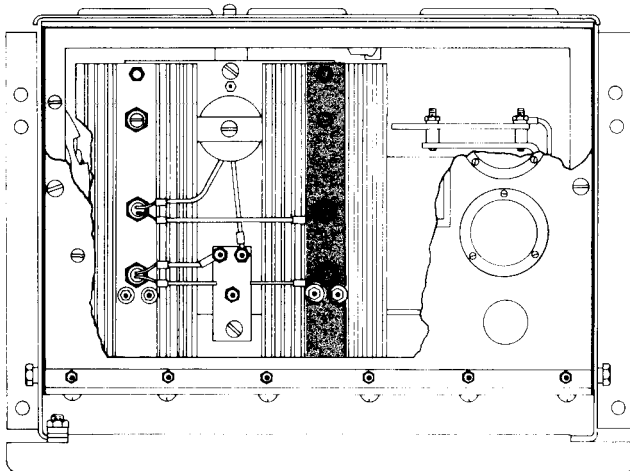

## REPLACE

- Install new diode.
- Tighten mounting nut to 20 inch-pounds torque with torque wrench.
- Replace heatsink:
  - Replace two machine screws at bottom.
  - Replace nuts, washers, spacers, and choke lead on 7/16" bolt at top of heatsink.
- Connect leads:
  - W16 to CR3;
  - W15 to CR2.

## 8. REACTOR L2

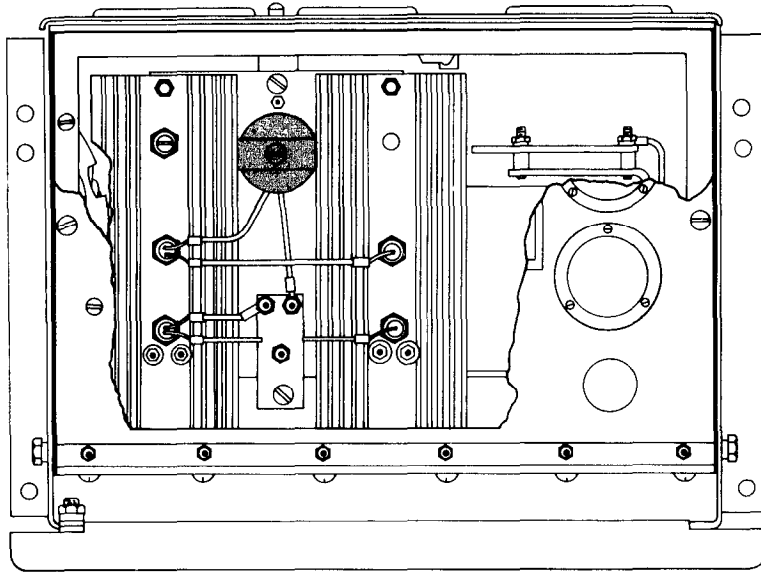

### REMOVE

- Remove top panel (para 2-10).
- Open front panel.
- Disconnect leads W17, W18.
- Remove mounting screw, washers on front, nut on rear.
- Remove bracket retaining screw, nut, nuts and washers.
- Slide reactor straight out.

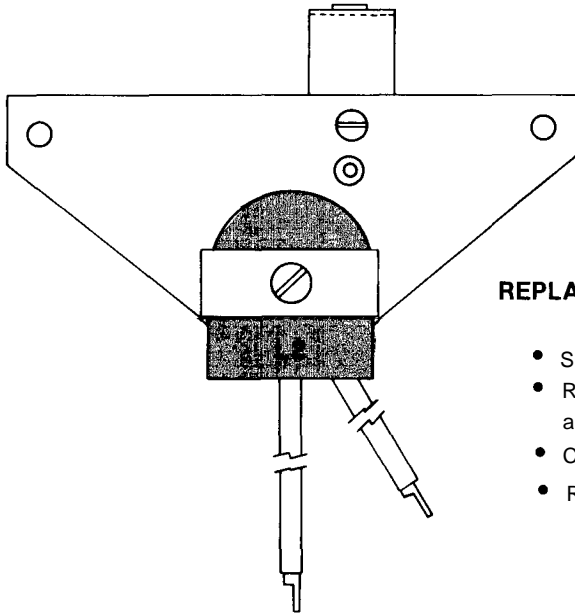

### REPLACE

- Slide new reactor into bracket.
- Replace bracket retaining screw, nut, nuts and washers.
- Connect leads W17, W18.
- Replace mounting screw, washers, nuts.

9. CAPACITORS C1, C2



Capacitors carry a charge after power supply is shut off.  
Short out capacitors with shorting rod.

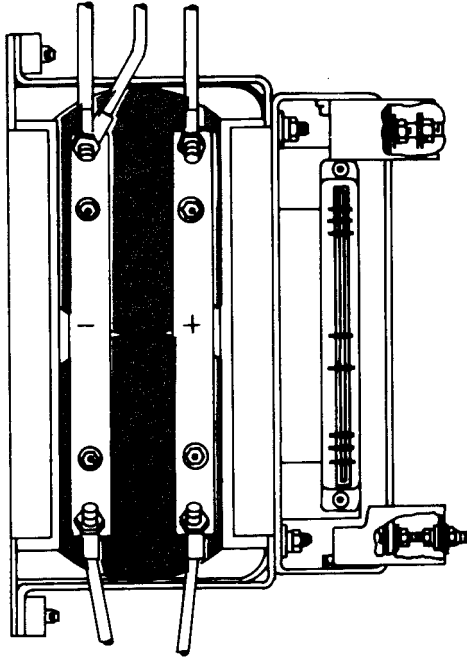

REMOVE

- Remove top panel.
- Remove left side panel. Remove six machine screws, three hex nuts.
- Remove four screws on side panel.
- Remove two screws from capacitor bank assembly side panel.
- Remove two screws from + and - bus bars of defective capacitor.
- Slide capacitor out.

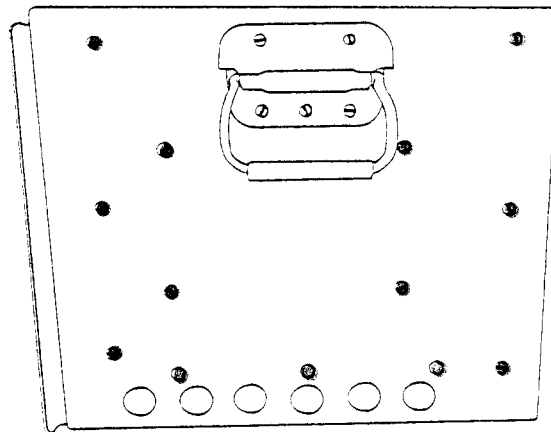

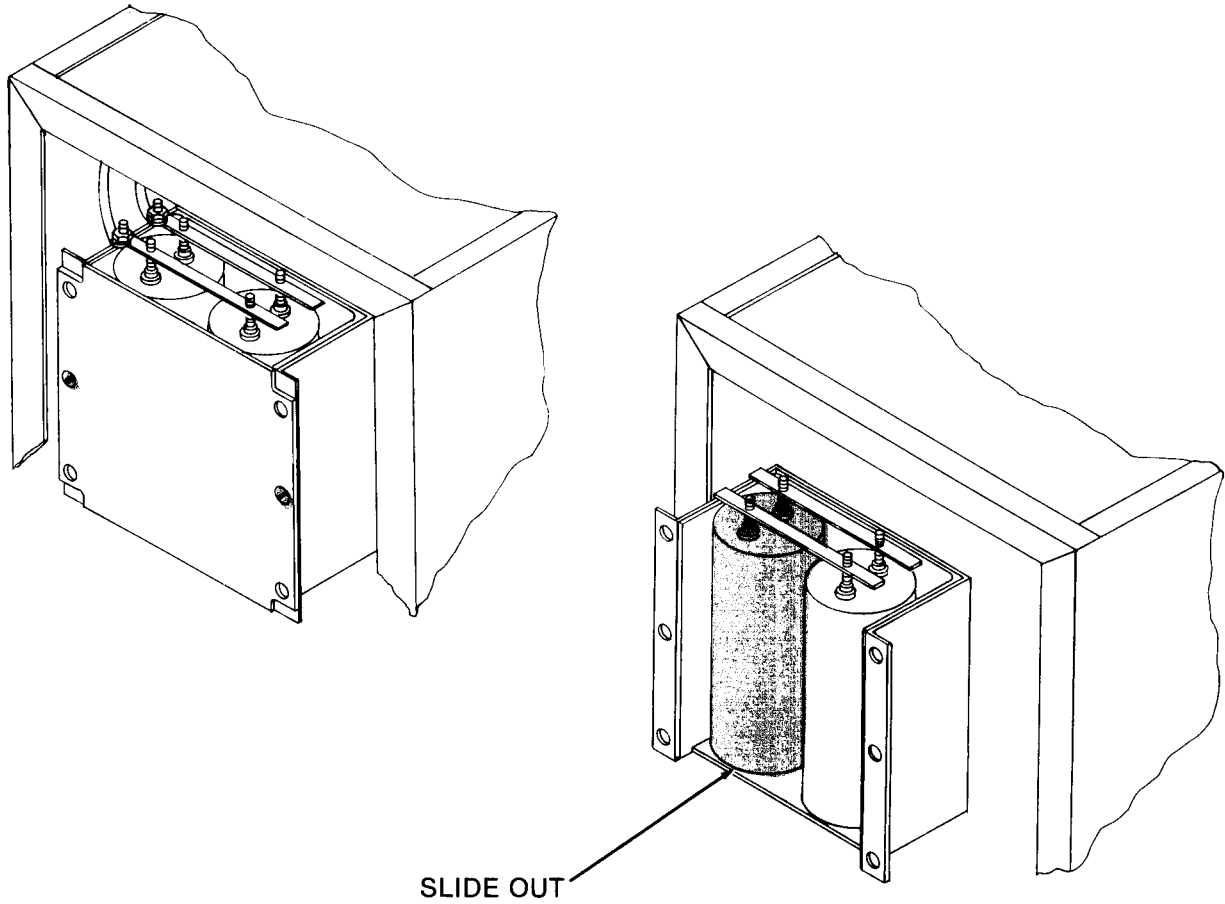

SLIDE OUT

CAUTION

Make sure positive marking (+) on capacitor goes to the positive marking (+) on bus bar.

#### REPLACE

- Slide new capacitor into assembly.
- Replace two screws of capacitor bank assembly.
- Replace power supply side panel.
- Remount capacitor bank assembly to side panel with four screws.

10. RESISTOR R3

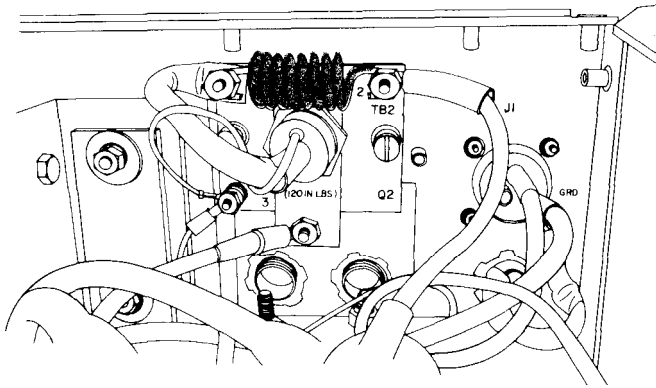

REMOVE

- Remove top panel (para 2-10).
- Remove nuts, washers.
- Tag and disconnect leads.
- Remove resistor.

REPLACE

- Install new resistor.
- Connect leads.
- Replace nuts, washers.
- Replace top panel.

11. DIODE SCR1 (Q1)

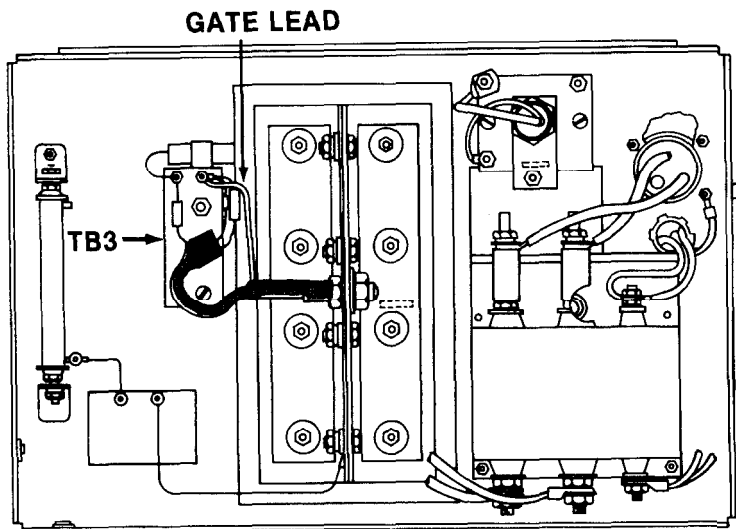

REMOVE

- Remove top panel (para 2-10).
- Unbolt rear panel.
- Disconnect leads and tag:
  - W6 from diode heatsink
  - W8 from TB3-2
  - W134 from TB3-1
  - POS wire from TB1 POS terminal
  - NEG wire from TB1 NEG terminal
  - L1, L2 from TB1 terminal L2 (PP-4763)
  - L1, L2 from TB1 terminal L2 (PP-4763A)
  - DC output terminal leads W136 from TB2-4.
- Remove mounting nut, washer.
- Remove diode.

REPLACE

- Apply thermal compound (Item No. 3 Appendix B) to mounting surface of heatsink.
- Install new SCR.
- Torque to 120 inch/pounds with torque wrench.
- Connect gate lead of SCR to TB3.
- Connect cathode lead of SCR to TB3.

12. DIODE SCR2 (Q2)



**REMOVE**

- Remove top panel (para 2-10).
- Remove W138 from TB2-3.
- Remove W12 from TB1-19.
- Remove W13 from TB1-18.
- Remove TB2 by removing two mounting screws.
- Remove cathode lead of SCR from TB2-1.
- Remove gate lead of SCR from TB2-3.
- Remove SCR mounting nut, washer, and lockwasher.

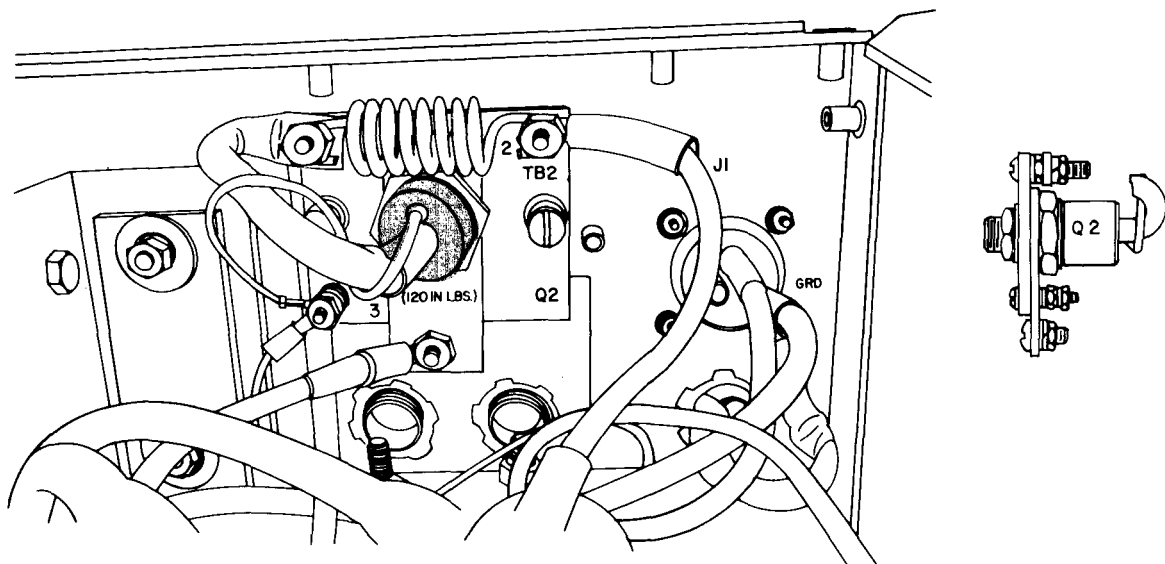

**REPLACE**

- Apply thermal compound (Item No. 3 Appendix B) to mounting surface of heatsinks.
- Install new SCR with washer, lockwasher, nut.
- Torque to 120 inch/pounds with torque wrench.
- Connect cathode lead of SCR to TB2-1.
- Connect gate lead of SCR to TB2-3.
- Replace TB2 to rear panel with two mounting screws.
- Connect W138 to TB2-3.
- Connect W12 to TB1-19.
- Connect W13 to TB1-18.
- Replace top cover.



**13. AC CABLE W3**

**REMOVE**

- Remove top panel (para 2-10).
- Remove rear panel.
- Remove cable connector:
  - Remove machine screws.
  - Remove connector clamps.
- Remove nuts, washers.
- Disconnect three cable connections.
- Remove cable.

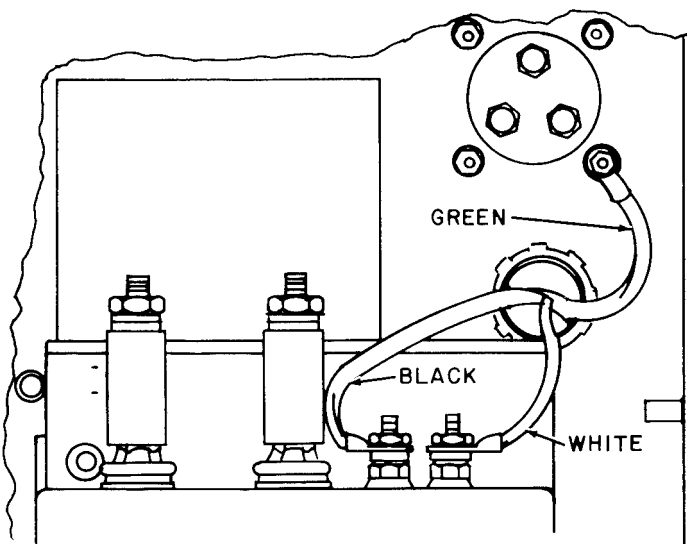
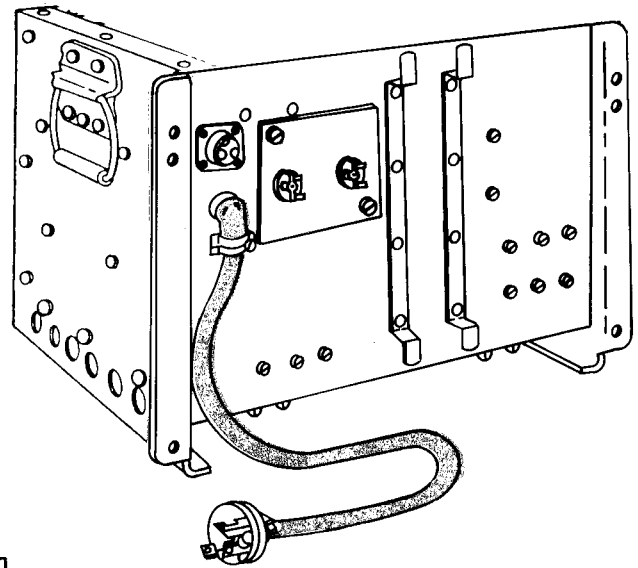

**REPLACE**

- Install new cable.
- Replace cable connections.
- Replace nuts, washers.
- Replace cable connector clamps.
- Replace machine screws.
- Replace rear panel.
- Replace top panel.

**14. AC CABLE PLUG W3P1 (PP-4763A)**

**REMOVE**

- Remove screws.
- Remove cable plug clamp.
- Remove cover insulator.
- Disconnect leads inside.
- Remove cable plug.

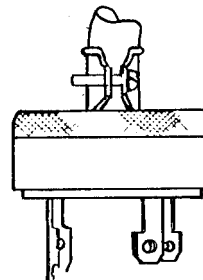

**REPLACE**

- Install new cable plug.
- Connect leads inside plug.
- Replace cover insulator.
- Replace cable plug clamp.
- Replace screws.

**NOTE**

Make sure connections are correct.

15. FAN MOTOR B1



**REMOVE**

- Remove top panel (para 2-10).
- Remove chassis plate from top panel: remove four machine screws, nuts, washers.
- Remove fan motor assembly from chassis plate: remove four screws, nuts washers.

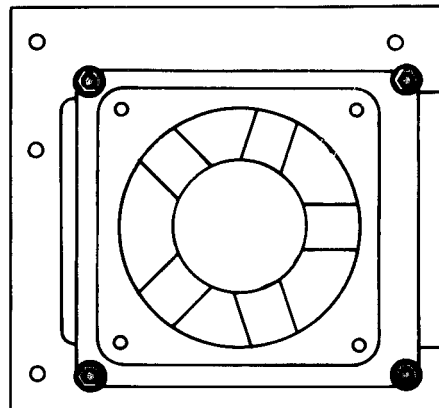
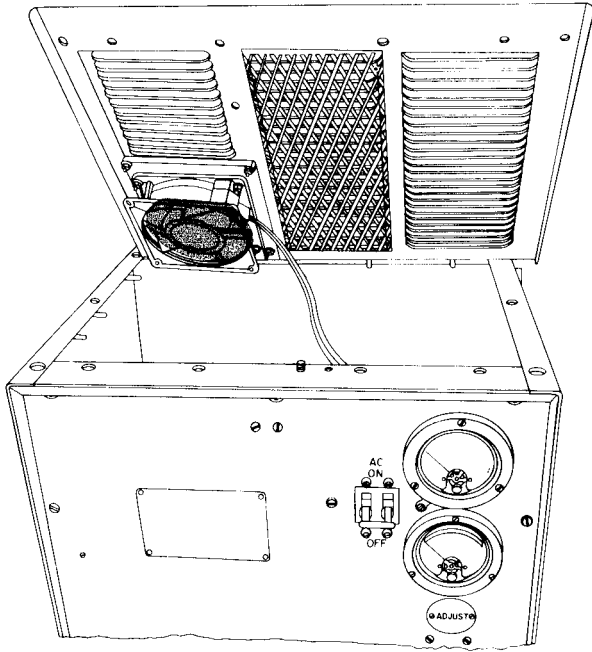

**REPLACE**

- Install new fan motor assembly onto chassis plate: replace four machine screws, nuts, washers.
- Replace chassis plate on panel: replace four machine screws, washers, nuts.

16. TRANSFORMER T1

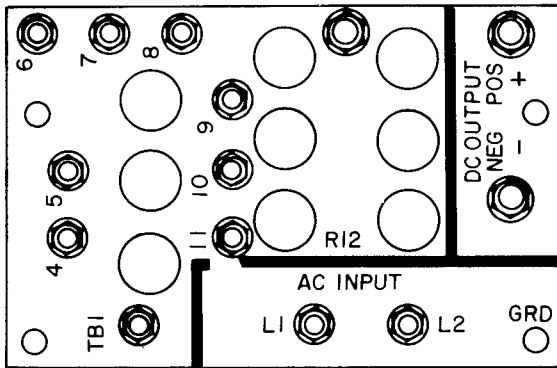

(FOR PP-4763/GRC)

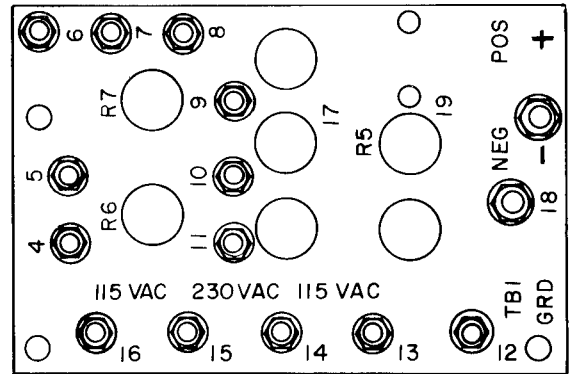

(FOR PP-4763A/GRC)

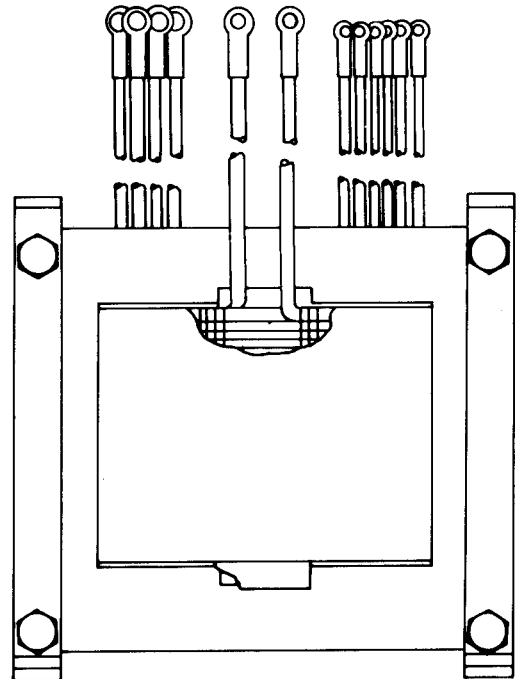
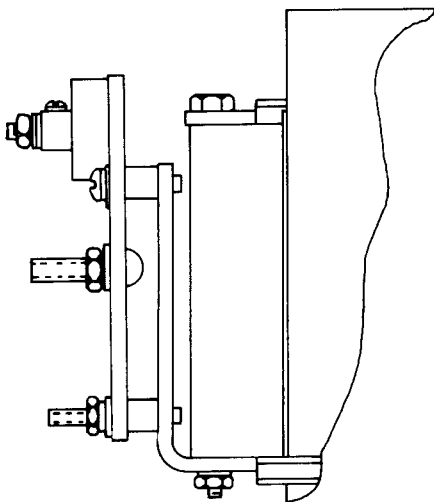

TRANSFORMER T1

REMOVE

- Remove top panel, rear panel; open front panel (para 2-10).
- Disconnect leads W70 and W71 from terminals TB4-1 and TB4-2.

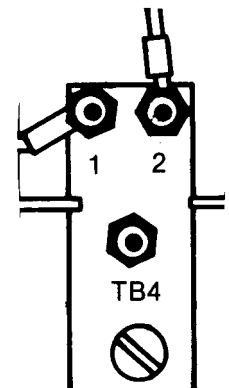

**PP 4763**

- Remove nuts, washers, studs, and standoffs that secure TB1 to transformer.
- Remove all wires from TB1 and tag.
- Use ratchet, 7/16" socket and extension to remove four nuts from transformer frame assembly
- Lift transformer over rear mounting bracket and carefully remove.

**PP 4763A**

- Remove nuts, washers, studs, and standoffs that secure TB1 to transformer.
- Remove wires from TB1 at 12, 13, 14, 15, 16, 6, 7, 8, 10, 11, and tag.
- Use ratchet, 7/16" socket and extension to remove four nuts from transformer frame assembly.
- Lift transformer over rear mounting bracket and carefully remove.

**REPLACE**

**PP 4763**

Carefully install new transformer

- Replace four nuts on transformer frame assembly.
- Replace all leads.
- Reattach TB1 to transformer:  
Replace nuts, washers, studs, standoffs.

**PP 4763A**

- Carefully install new transformer.
- Replace four nuts on transformer frame assembly.
- Replace leads on TB1 at 12, 13, 14, 15, 16, 6, 7, 8, 10, 11, and tag.
- Reattach TB1 to transformer:  
Replace nuts, washers, studs, standoffs.

**17. DIODE CR6**



**REMOVE**

- Remove top panel (para 2-10).
- Open front panel.
- Unsolder and tag:  
W54 from TB 4-1  
W53 from TB 4-2
- Remove diode mounting nut.
- Lift diode out from rear of terminal board.

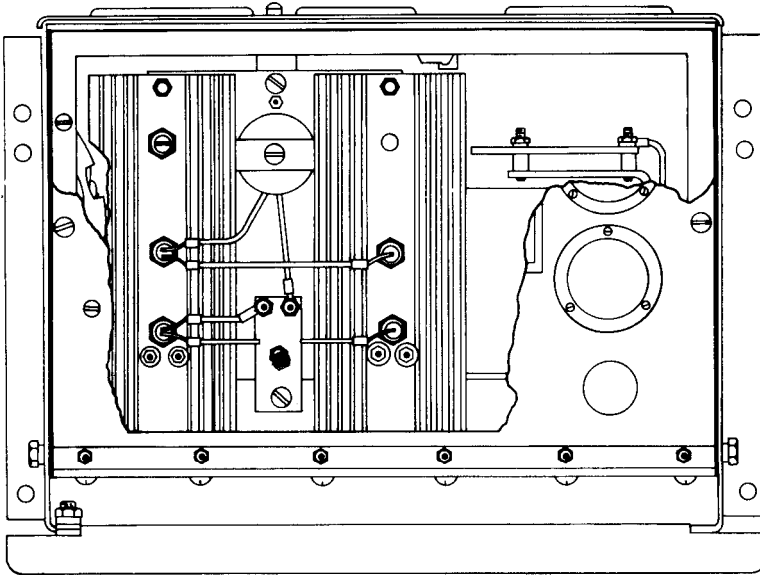

**NOTE**

Install diode on rear of terminal board only.

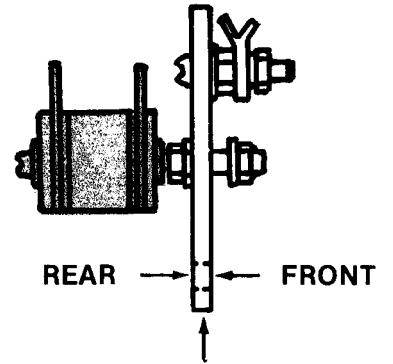

**REPLACE**

- Install new diode.
- Replace diode mounting nut.
- Solder and tag:
  - W54 to TB 4-1
  - W53 to TB 4-2

**18. INTERLOCK SWITCH**



**REMOVE**

- Remove top panel (para 2-10).
- Remove two screws holding switch assembly.
- Disconnect and tag two leads.

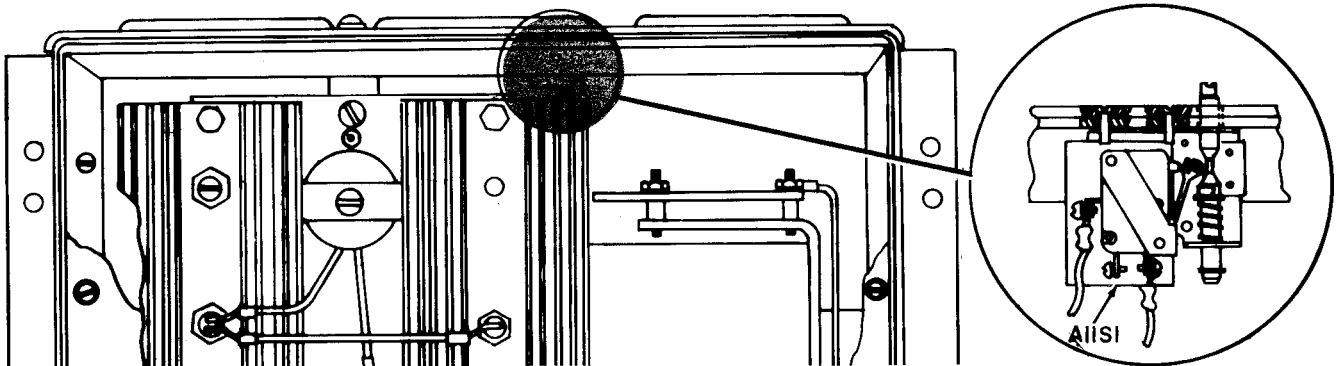

**REPLACE**

- Connect and tag two leads.
- Replace two screws holding switch assembly.
- Replace top panel.

## Section IV. TEST PROCEDURES

### 2-12. PROCEDURES

Perform tests listed below after performing maintenance on equipment. These tests determine if equipment has been properly repaired and can be returned to use. Repaired equipment must meet performance standards given on page 2-48.

#### Use of test charts:

- Read instructions carefully before using chart.
- Perform each step in sequence. DO NOT vary sequence.
- Perform all required actions.
- Perform each test procedure.
- Check each procedure against its performance standard.

Tools, test equipment, and materials: refer to page 2-1.

### 2-13. PHYSICAL TESTS AND INSPECTIONS

#### General

Disconnect power supply from power source and other equipment.  
Test equipment and materials: None required.  
Test connections and conditions: No connections necessary.

#### Procedures

Control settings: AC power switch may be in any position.  
Legend: Test Procedures  
Performance Standard

#### Test Chart

- (1) Check case for damage, missing parts, condition of paint:
  - No damage to case, no parts missing.
  - Surfaces needing paint do not show bare metal.
  - Panel lettering readable.
- (2) Remove top panel (para 2-10):
  - Check chassis for damage, missing parts.
  - No damage or missing parts.
  - Check mechanical assemblies for loose or missing screws, bolts, nuts.
  - Screws, bolts, nuts are tight. None missing.
  - Check all electrical assemblies for loose or missing parts.
  - Parts are tight. None missing.
- (3) Operate power switch:
  - Operates properly.
- (4) Turn motor B1 fan blades:
  - Blades turn freely without sticking.

- (5) Check ac cable assembly:  
Insulation not frayed or damaged.
- (6) Check ac cable W3P1 (PP-4763A):  
Plug securely attached to cable, not damaged.
- (7) Resistance check of interlock switch S1:  
Operates properly (refer to  ).  
S1 open reading is 0 ohms.  
S1 closed reading is 2.2K.  
Replace top panel.

**2-14. STATIC VOLTAGE REGULATION TEST**

**Test Equipment and Materials**

- Transformer TF-171/USM
- Voltmeter AN/USM-98A
- Voltmeter ME-30(\*)/U
- Test switch (single-pole, 60 ampere)
- Resistor, 0.56 ohm, 1000 watts
- Resistor, 1.3 ohms, 1000 watts

**Test Connections and Conditions**

Connect test equipment as shown.

**CAUTION**

For PP-4763A, set ac input links to 115-volt operation before connecting power supply and test equipment to source (para 2-10).

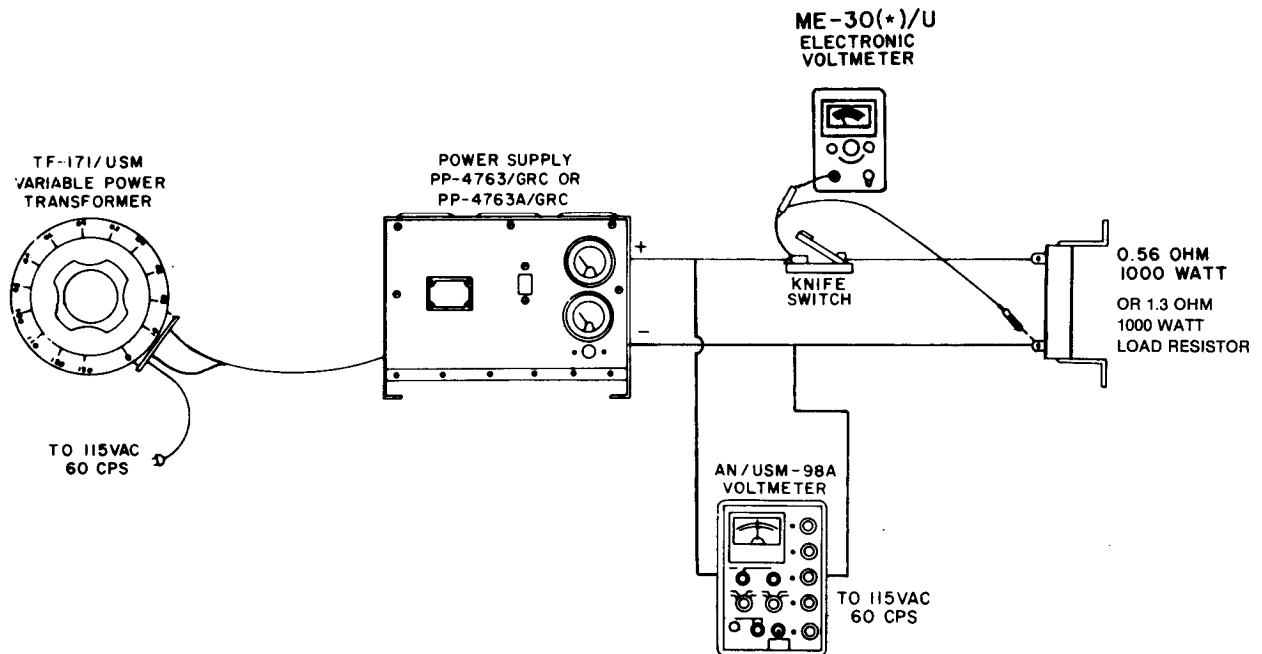

TEST EQUIPMENT SETTINGS:

Transformer	Control: 115 volts
Multimeter	FUNCTION switch: AC VOLTS, 250 VOLT SCALE Black test lead: OHMS – DC + AC jack Red test lead: 2.5 jack, 1000 OHMS PER VOLT AC DC column
Voltmeter AN/USM-98A	Range: 50 volt Null: VTVM
Voltmeter ME-30(*)/U	Switch: 0.3 volts (calibrated)
Load	0.56 ohm, 1000-watt resistor
Test switch	Open

**NOTE**

Keep test equipment at these settings except where noted.

- |  |  |
|--|--|
| (1) Equipment set as noted above.                              | Circuit breaker CB1 ON.<br>Set dc voltage adjust R4 for 28-volt output.                  |
| 1 Check accuracy of voltmeter MI; compare AN/USM-98A readings. | Less than 1.0 volt difference between readings.  |
| 2 Close test switch. Check ripple voltage on ME-30(*)/U.       | Voltage within 1% rms (approximately 3% peak to peak) of output voltage.                 |
| 3 Check dc output voltage on AN/USM-98A.                       | Reading within +0.5% of 28 volts dc (maximum voltage deviation 280 millivolts or less).  |
| (2) Transformer: 127 volts.<br>Test switch closed.             | DC voltage: 28 volts.<br>Reading within +0.5% of 28 volts dc (280 mV or less deviation). |
| Check dc voltage output on AN/USM-98A.                         |  |
| (3) Load: 1.3 ohm, 1000-watt resistor.<br>Test switch closed.  | DC voltage adjust: 28 volts.   |
| Check dc output voltage.                                       | Reading within +0.5% of 28 volts dc (280 mV or less deviation).                          |



**TEST EQUIPMENT**

**EQUIPMENT UNDER TEST**

**TEST PROCEDURE**

**PERFORMANCE STANDARD**

(4) Transformer: 103 volts.  
 Load: 1.3-ohm resistor.  
 Test switch closed.  
 Check dc output voltage.

DC voltage: 28 volts

Reading within +0.5% of 28 volts dc (280 mV or less deviation).

(5) Transformer: 127 volts.  
 Load: 1.3-ohm resistor.  
 Test switch closed.  
 Check dc output voltage.

DC voltage: 28 volts

Reading within +0.5% of 28 volts dc (280 mV or less deviation).

(6) Test switch open.  
 Load reduced to zero.  
 Check dc output voltage.

DC voltage: 28 volts

Reading within +0.5 % of 28 volts dc (280 mV or less deviation).

(7) Transformer: 103 volts.  
 Test switch open.  
 Load reduced to zero.  
 Check dc output voltage.

DC voltage: 28 volts

Reading within +0.5 % of 28 volts dc (280 mV or less deviation).

(8) Transformer: 127 volts.  
 Test switch open.  
 Load reduced to zero.  
 Check dc output voltage.

DC voltage: 28 volts

Reading within +0.5% of 28 volts dc (280 mV or less deviation).

(9) Load: 1.3-ohm resistor.  
 Test switch closed.  
 Check dc output voltage.

DC voltage: Set for minimum voltage (full Cw).

Reading between 22 and 27 volts dc.

(10) Load: 1.3-ohm resistor.  
 Test switch closed.

DC voltage: Set for maximum voltage (full c w).

Check dc output voltage.

Reading between 29 and 30 volts dc.

RESET DC VOLTAGE ADJUST FOR 28-VOLT OUTPUT  $\pm$  0.1 VOLT

CIRCUIT BREAKER: OFF

TURN OFF POWER TO ALL TEST EQUIPMENT.

**Verifying PP-4763A 230-volt input**

The above voltage regulation test was conducted at 115 volts. If a 230-volt, single-phase, 50/60 Hz power source is available, test PP-4763A at 230-volt input.

**Procedure:**

- Set TB-1 ac input links to 230 volts ac.
- Connect power cable to 230-volt source.
- Repeat test equipment settings, control settings for step 1 of paragraph 2-14 in test chart.
- Repeat ripple voltage, dc output voltage checks in step 1 of paragraph 2-14.

**2-15. TEST DATA SUMMARY**

Summary of performance standards.

<b>Input</b>		
Voltage	115 volts	PP-4763
	115 or 230 volts	PP-4763A
Frequency	50/60 Hz	
Phase	Single	
Current (full load)	23 amperes	PP-4763
	23 amperes at 115-volt input	PP-4763A
	11.5 amperes at 230-volt input	

<b>Output</b>	
Voltage	28-volt operation (27-29 volts dc)
Current (full load)	50 amperes
Ripple Voltage (maximum)	1.0 percent rms

**Voltage Regulation**  
 Static voltage: \*0.5 percent (maximum total voltage deviation 280 millivolts).

**CHAPTER 3**  
**GENERAL SUPPORT MAINTENANCE**

**Section I. GENERAL INFORMATION**

	PAGE
General . . . . .	3-2
Repair Parts, Tools, Test Equipment, and Materials . . . . .	3-2

**Section II. TROUBLESHOOTING**

Procedures . . . . .	3-3
Testing and Troubleshooting Circuit Card Assembly PC101(A1) . . . . .	3-3

**Section III. MAINTENANCE PROCEDURES**

Removing and Replacing Circuit Card Assembly PC101(A1) . . . . .	3-6
Repairing Circuit Card Assembly PC101(A1) . . . . .	3-6

**Section IV. TEST PROCEDURES**

Dynamic Voltage Regulation Test . . . . .	3-10
Procedures . . . . .	3-10
Test Data Summary . . . . .	3-13



**Section I. GENERAL INFORMATION**

**3-1. GENERAL**



Low voltage, high amperage current is present at output connections and connections inside equipment.

Shut off power supply before performing maintenance.

Be careful when working with 115 or 230-volt ac line connections.

Serious injury or death may result from contact with terminals.

This chapter covers general support troubleshooting, maintenance, and testing procedures for the power supply. Section I lists the tools, test equipment, and materials needed to perform general support maintenance. Troubleshooting procedures are described in Section II, maintenance procedures in Section III, and test procedures in Section IV.

**NOTE**

This chapter is confined to maintenance of circuit card assembly PC101(A1). For all other maintenance instructions, see Chapter 2.

**3-2. REPAIR PARTS, TOOLS, TEST EQUIPMENT, AND MATERIALS**

Repair Parts: Refer to TM 11-5820-765-34P-1.

Special Tools: No special tools are needed.

Tools, Test Equipment, and Materials:

<b>Item</b>	<b>National Stock Number</b>
<b>TOOLS</b>	
Tool Kit, Electronic Equipment TK-100/G	5180-00-605-0079
Tool Kit, Electronic Equipment TK-105/G	5180-00-610-8177
Torque Wrench, 150 inch-pounds	5120-00-230-6380
<b>TEST EQUIPMENT</b>	
Multimeter TS-352B/U	6625-00-553-0142
Ohmmeter ZM-21A/U	6625-00-643-1030
Oscilloscope AN/USM-281A	6625-00-228-2201
Transformer, Variable Power TF-171/USM	6120-00-503-0632
Voltmeter, Electronic AN/USM-98A	6625-00-753-2115
Voltmeter, Electronic ME-30(*)/U	6625-00-643-1670

**MATERIALS**

Resistor, 0.56 ohm, 1000 watts

Resistor, 1.3 ohms, 1000 watts

5905-00-064-4679

Test Switch, Single-Pole, 60 ampere

Wire, Electrical, Stranded; No. 8 AWG

**Section II. TROUBLESHOOTING****3-3. PROCEDURES**

Follow procedures in Chapter 2 to localize and isolate trouble. Use paragraph 3-4 to test and troubleshoot the circuit card assembly.

**3-4. TESTING AND TROUBLESHOOTING CIRCUIT CARD ASSEMBLY PC101(A1).**

Capacitors carry a charge after power supply is shut off.

Before performing tests:

Shut off power supply.

Disconnect from ac power source.

Discharge capacitors by shorting out with shorting rod.

**General Instructions**

Remove top panel (para 3-5).

Make visual check for overheated components or circuits. If there is visual evidence, check suspected circuit card component with multimeter.

If there is no evidence of overheating, remove circuit card from the unit (para 3-5) and examine it. If the board is blistered, cracked, or broken, the board must be replaced. You can replace defective components and repair cracked or open-circuited wiring.

**Resistance Measurements**

Test equipment: Multimeter TS-352B/U

**Checking PC101**

Measure: Resistance of assembly components.

Connection: Location of connector terminals PC101:

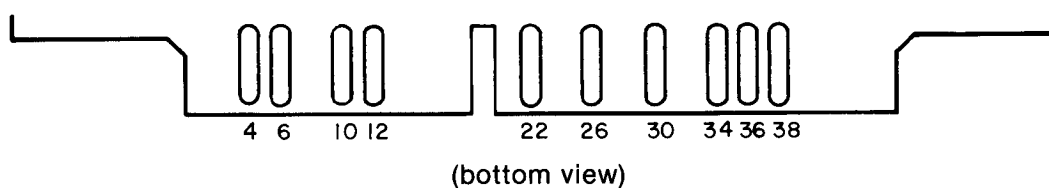

**Test procedure:**

PC101J101 Between terminals	Forward resistance	Reverse resistance
12-30	10K	Higher (greater than 20K)
12-26	10K	Higher (greater than 20K)
4-6	1 K - 4 K	1 K - 4 K
12-34	11K	Infinity
26-30	45K	45K
6-12	Zero	Zero
6-36	High (greater than 10K)	High (greater than 10K)
6-38	High (greater than 10K)	High (greater than 10K)
10-22	High (greater than 10K)	High (greater than 10K)
10-12	14K	200K

**Checking A1 (PP-4763-A)**

Measure: Resistance of assembly components.

Test points: A1TP1 through A1TP6.

Connections: Location of test points:

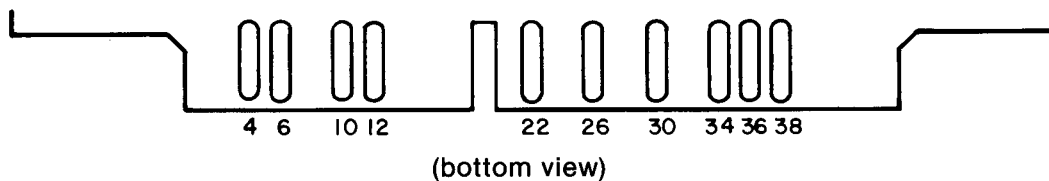

Make same resistance measurements as above (refer to fig. 2, para 3-6).

Make direct resistance measurements of A1 components, using these test points:

A1 Test Points Between	A1J101 Terminals	Forward Resistance	Reverse Resistance
A1TP3	34	400K	Infinity
A1TP2	12	0	14K
A1TP5	12	220Ω	1560Ω
A1TP1 to A1TP2	.....	50K	Infinity
A1TP6	12	0	100K
A1TP4	6	2.1 K	2.5K

**Voltage and Oscilloscope Measurements, A1 (PP-4763A)**

Test equipment: Oscilloscope AN/URM-140A  
 Voltmeter, Electronic ME-30(\*)/U

Measure: Characteristic voltages, wave shapes.

**NOTE**

Use extender board; if none available, modify a test lead for voltage or wave shape.

**A1 TEST POINTS BETWEEN**

**VOLTAGE OR WAVE SHAPE**

TB1-8 A1TP5

20 volts dc

A1TP2 TB1-8

20 volts dc

A1TP6 TB1-8

9 volts dc

TB2-4 A1TP6

9 volts dc

**A1TP1 TB1-8**

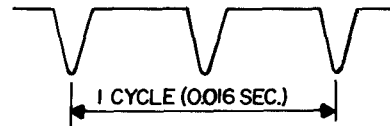

**A1 TEST POINTS BETWEEN**

**VOLTAGE OR WAVE SHAPE**

**A1TP3 TB3-1**

**FULL LOAD**

**NO LOAD**



Section III. MAINTENANCE PROCEDURES

3-5. REMOVING AND REPLACING CIRCUIT CARD ASSEMBLY PC101(A1)

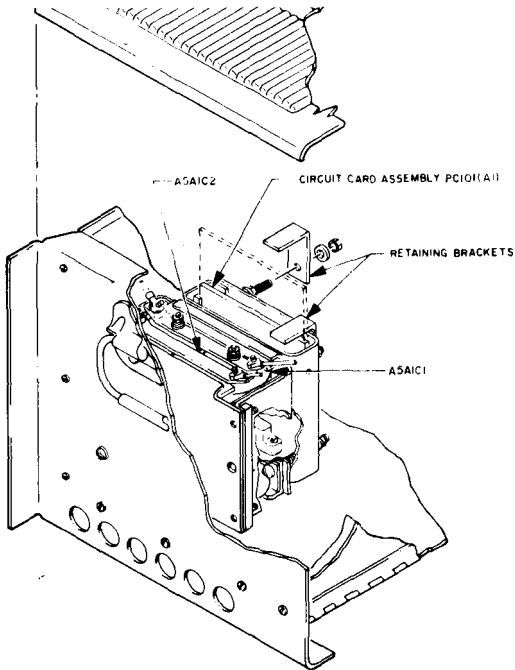

**REMOVE**

- Remove top panel:  
Remove 15 machine screws, nuts, washers.  
Disconnect fan motor plug.
- Remove retaining bracket nuts, washers.
- Remove retaining brackets.
- Lift circuit card assembly straight up from socket.

**CAUTION**

Be careful not to break solder connections when pulling the circuit card.

**REPLACE**

- Insert circuit card into socket.
- Be sure that the circuit card terminal points are set all the way into the socket.
- Replace retaining brackets, nuts, washers.

3-6. REPAIRING CIRCUIT CARD ASSEMBLY PC101(A1) (figs. 1 and 2)

Removing Protective Coating



Adequate ventilation should be provided while using TRICHLOROTRIFLUOROETHANE. Prolonged breathing of vapor should be avoided. The solvent should not be used near heat or open flame; the products of decomposition are toxic and irritating. Since TRICHLOROTRIFLUOROETHANE dissolves natural oils, prolonged contact with skin should be avoided. When necessary, use gloves which the solvent cannot penetrate. If the solvent is taken internally, consult a physician immediately.

**CAUTION**

Before starting repairs, remove protective coating EC1103 from the circuit card assembly:

- Isolate the area to be repaired.
- If this area is small, scrape off the protective coating with a knife or other sharp tool.
- If this area is large, soak the circuit card in TRICHLOROTRIFLUOROETHANE to soften the coating, then wipe the area clean with a lint-free cloth.



CIRCUIT CARD ASSEMBLY PC101

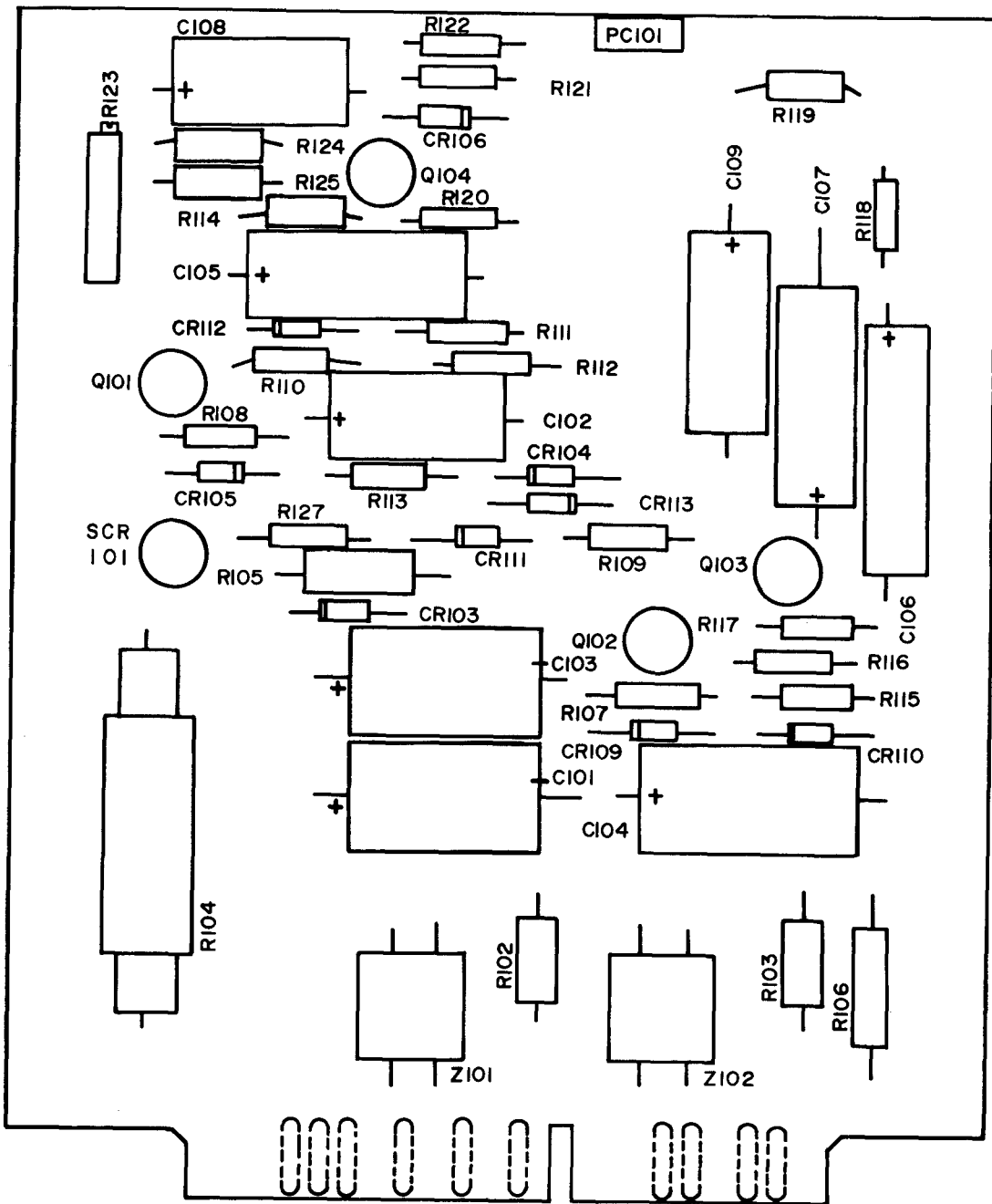

FIGURE 1

CIRCUIT CARD ASSEMBLY PC 101 (A1)

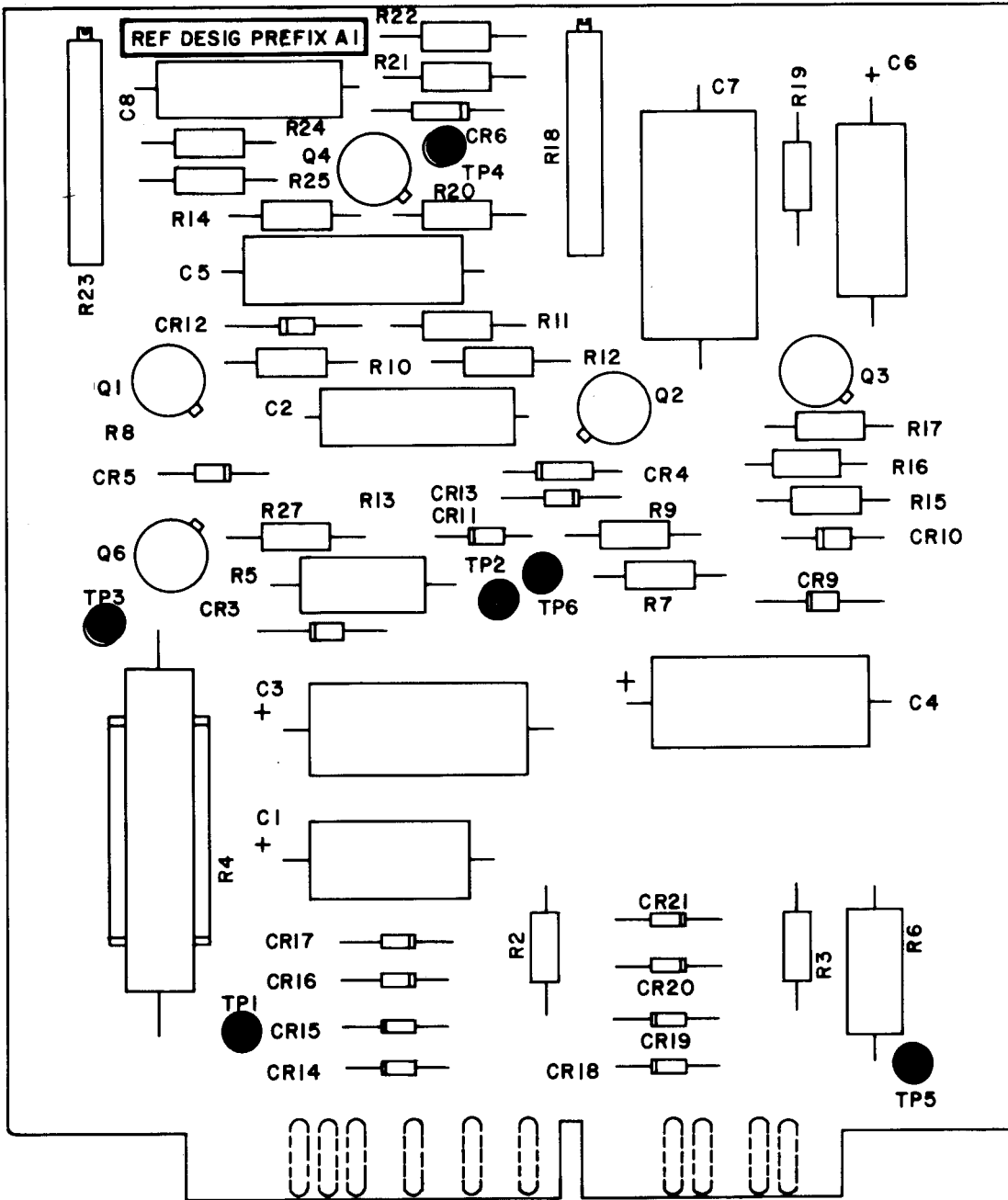

FIGURE 2

## Repairing Printed Circuit Wiring

### CAUTION

Use only a pencil-type soldering iron with a maximum rating of 25 watts. Excessive heat will cause printed wiring conductors to separate from the board. For additional soldering techniques, refer to TB SIG 222.

Repair printed circuit wiring that has a crack, pinhole, cut, or notch more than 30 percent of the wire's width.

#### Procedure:

- Remove protective coating.
- Place a short length of flat bus wire over the defective wiring and hold it firmly in place.
- Solder the entire length of bus wire to the wiring.

### CAUTION

Do not apply heat longer than needed. Prolonged heat can separate the conductor from the card; this damage cannot be repaired.

- Apply protective coating to exposed area after completing repairs.

### Replacing Defective Parts

- Remove defective part:
  - Cut leads on part between part and circuit card mounting holes.
  - Cut leads as close to mounting holes as possible.
- Remove protective coating around the part on the card's printed wiring side.
- Heat printed wiring at mounting holes with soldering iron until solder melts.
  - Remove excess solder and remaining pieces of wire leads.

### CAUTION

Do not apply heat longer than needed. Prolonged heat can separate the printed wiring from the card, which will damage the card.

- Bend the leads of replacement part to fit mounting holes.
- Insert leads in mounting holes from parts side of card; press part firmly against card.
- On card's wiring side, cut leads of part; leave approximately 1/8 inch of leads protruding from card.
- Bend and press these leads against printed circuit conductor
- Using a heat sink, solder replacement part leads to printed circuit conductor.
- Apply protective coating to repaired area.

### Applying protective Coating

After completing repairs, apply protective coating to all exposed areas on circuit card.



Protective coating EC1103 is toxic.

The work area must be well ventilated.

Avoid breathing the fumes.

If the coating comes in contact with skin, immediately wash the skin with soap and water.

- Use a rubber eraser to clean areas to be coated.
- Prepare the protective coating mixture:
  - Mix 70 parts protective coating (Item No. 2, Appendix B) with 30 parts naphtha (parts by volume) (Item No. 4, Appendix B). Stir mixture thoroughly.
- Apply coating mixture to card by spraying, dipping, or brushing.
  - When brushing, be careful to prevent bubbles from forming.
- Set coated card aside; allow it to dry in fresh air for five hours.

## Section IV. TEST PROCEDURES

### 3-7. PROCEDURES

After performing maintenance on circuit card assembly, perform static voltage regulation test (para 2-14) and dynamic voltage regulation test below. Repaired equipment must meet performance standards given on page 3-11.

### 3-8. DYNAMIC VOLTAGE REGULATION TEST

#### Test Equipment and Materials

Multimeter TS-352B/U  
Oscilloscope AN/USM-281A  
Transformer TF-171/USM  
Voltmeter AN/USM-98A  
Voltmeter ME-30(\*)/U  
Resistor, 0.56 ohm, 1000-watt  
Test switch, single-pole, 60 ampere

Test Connections and Conditions

Connect test equipment as shown.

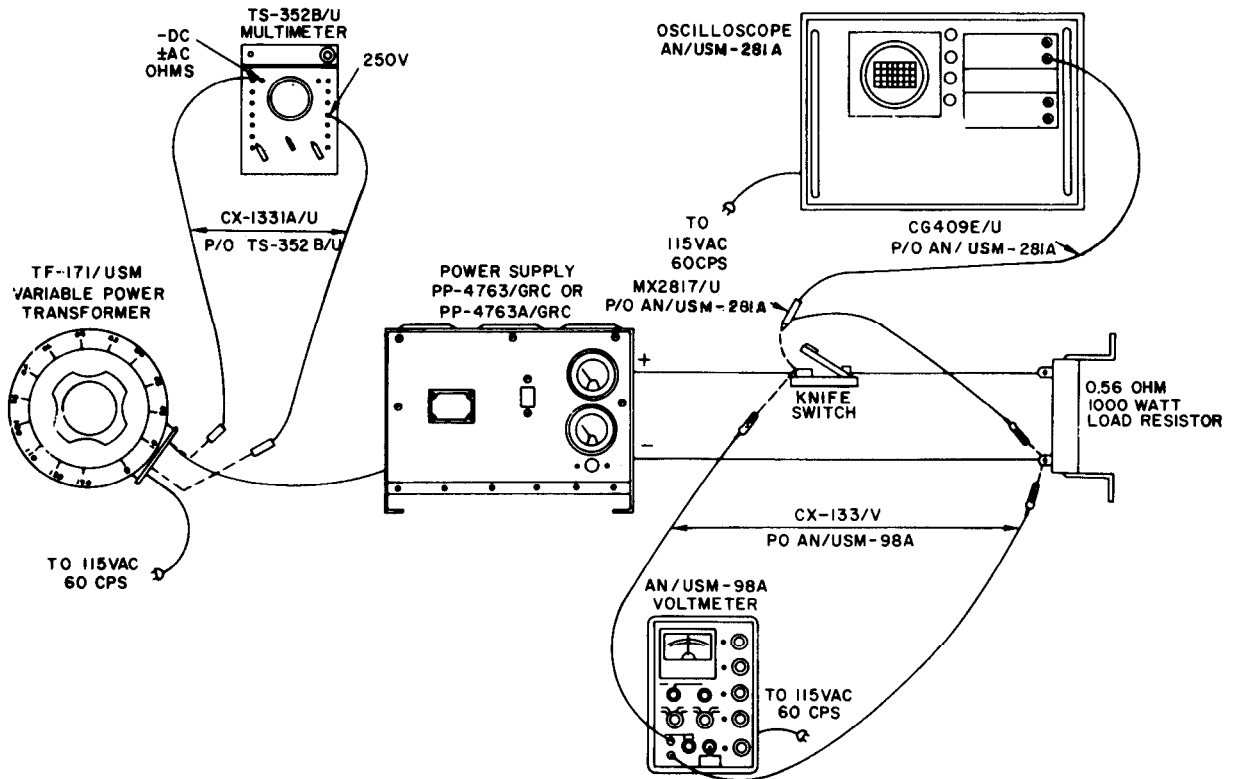

**CAUTION**

For PP-4763A, set ac input links to 115 volt operation before connecting power supply and test equipment to source.

**TEST LEGEND**

**TEST EQUIPMENT**

**EQUIPMENT UNDER TEST**

**TEST PROCEDURE**

**PERFORMANCE STANDARD**

**TEST EQUIPMENT SETTINGS:**

Transformer

Control: 115 volts

Multimeter

FUNCTION switch: AC VOLTS, 250 VOLT SCALE

Black test lead: OHMS -DC ±AC jack

Red test lead: 2.5 jack, 1000 OHMS PER VOLT

AC-DC column

Voltmeter AN/USM-98A

Range: 50 volt

Null: VTVM

Polarity: Set so 50 VOLTS meter indicator deflects to right during test.

Load

0.56 ohm, 1000-watt resistor

Test switch

Open

TEST LEGEND

TEST EQUIPMENT

EQUIPMENT UNDER TEST

TEST PROCEDURE

PERFORMANCE STANDARD

NOTE

Keep test equipment at these settings except where noted.

- |  |  |
|--|--|
| 1. Equipment set as noted above.                                 | Power ON.<br>DC voltage adjust R4; 28-volt output.   |
| 2. Close test switch.<br>Check dynamic response on oscilloscope. | Transient voltage less than 5 volts.<br><br>Response times:<br>PP-4763: Recovery to within 1.85 volts of final value less than 50 milliseconds.<br>PP-4763A: Recovery to within 37 percent of final value less than 75 milliseconds.     |
| 3. Open test switch.<br>Check dynamic response on oscilloscope.  | Transient voltage less than 5 volts.<br><br>Response times:<br>PP-4763: Recovery to within 1.85 volts of final value less than 100 milliseconds.<br>PP-4763A: Recovery to within 37 percent of final voltage less than 125 milliseconds. |
| 4. Power OFF.<br>Check dynamic response on oscilloscope.         | DC voltage overshoot less than 5 volts.  |
| 5. Power ON.<br>Check dynamic response on oscilloscope.          | DC voltage overshoot less than 5 volts.  |

**Power OFF. Turn off power to all test equipment.**

**3-9. TEST DATA SUMMARY**

Summary of performance standards.

**Input**

Voltage	115 volts	PP-4763
	115 or 230 volts	PP-4763A
Frequency	50/60 Hz	
Phase	Single	
Current		
(full load)	23 amperes	PP-4763
	23 amperes at 115-volt input	PP-4763A
	11.5 amperes at 230-volt input	

**Output**

Voltage	28-volt operation (27-29 volts dc)
Current (full load)	50 amperes
Ripple Voltage (maximum)	1.0 percent rms

**Voltage Regulation**

Static:  $\pm 0.5$  percent (maximum total voltage deviation 280 millivolts)

**Dynamic voltage regulation**

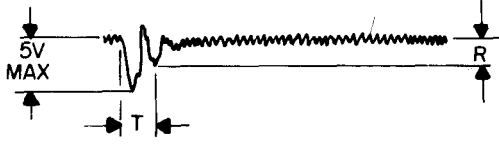
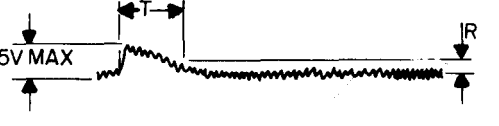
PP-4763	Response time (milliseconds)	Recovery Value
Full load	50	Within 1.85 volts from final value
		
Load OFF	100	
		
PP-4763A		
Full load	75	Within 137 percent of final value
Load OFF	125	





**APPENDIX A**

**REFERENCES**

**A-1. INTRODUCTION**

Following is a list of all forms, technical bulletins, and technical manuals referenced in this manual.

**A-2. FORMS**

Quality Deficiency Report . . . . . SF 368  
 Recommended Changes to Equipment Technical Manuals . . . . . DA Form 2028-2  
 Recommended Changes to Publications and Blank Form . . . . . DA Form 2028

**A-3. TECHNICAL BULLETINS**

Solder and Soldering . . . . . TB SIG 222  
 Safety Precautions for Maintenance of Electrical/Electronic Equipment . . . . . TB 385-4

**A-4. TECHNICAL MANUALS**

Direct Support and General Support Maintenance Repair Parts and Special  
 Tools Lists (Including Depot Maintenance Repair Parts and Special  
 Tools) for Power Supplies PP-4763/GRC (NSN 5820-00-937-7690) and  
 PP-4763A/GRC(NSN 5820-00-13768), . . . . . TM 11-5820-765-34P-1  
 Operator's and Organizational Maintenance Manual: Power Supplies,  
 PP-4763/GRC (NSN 5820-00-937-7690) and PP-4763A/GRC (NSN  
 5820-00-113-9768) . . . . . TM 11-5820-765-12  
 Operator's Manual: Radio Sets AN/GRC-106 (NSN 5820-00-402-2263) and  
 AN/GRC-106A(NSN 5820-00-223-7548) . . . . . TM 11-5820-520-10  
 Procedures for Destruction of Electronics Materiel to Prevent Enemy Use  
 (Electronics Command) . . . . . TM 750-244-2  
 The Army Maintenance Management System (TAMMS) . . . . . TM 38-750



APPENDIX B

EXPENDABLE SUPPLIES AND MATERIALS LIST

Section I. GENERAL INFORMATION

**B-1. INTRODUCTION**

This appendix lists expendable supplies and materials you will need to maintain PP-4763(\*)/GRC. These items are authorized by CTA 50-970, Expendable Items.

**B-2. EXPLANATION OF COLUMNS**

**a. ITEM NO.** This number is assigned to the entry in the listing and is referenced in the narrative instructions to identify the material (e.g., "Use cleaning compound, item 5, App B").

**b. LEVEL.** This column identifies the lowest level of maintenance that requires the listed item:

- F - Direct Support Maintenance
- H - General Support Maintenance

**c. NATIONAL STOCK NUMBER.** This is the National Stock Number assigned to the items; use it to request or requisition the item.

**d. DESCRIPTION.** Indicates the Federal item name and, if required, a description to identify the item. The last line for each item indicates the part number followed by the Federal Supply Code for Manufacturer (FSCM) in parentheses, if applicable.

**e. UNIT OF MEASURE (U/M).** Indicates the measure used in performing the actual maintenance function. This measure is expressed by a two character alphabetical abbreviation (e.g., ea, m, pr). If the unit of measure differs from the unit of issue, requisition the lowest unit of issue that will satisfy your requirements.

Section II. EXPENDABLE SUPPLIES AND MATERIALS LIST

(1) ITEM NO.	(2) LEVEL	(3) NATIONAL STOCK NUMBER	(4) DESCRIPTION	(5) U/M
1	F, H	6850-00-597-9765	Cleaning Compound for external surface	GAL
2	F, H	8030-00-165-6547	Sealing Compound: (FSCM 04963) Coating, Protective, EC1103	QT
3	F, H		Compound, thermal, Wakefield No. 128	GAL
4	F, H	6810-00-227-1271	Naphtha	GAL
5	F, H	6850-00-105-3084	Trichlorotrifluoroethane (80244)	OZ



INDEX

SUBJECT	A	PAGE
AC cable W3 . . . . .		2-39
AC cable plug W3P1 (PP 4763A). . . . .		2-39
AC input links (PP 4763A) . . . . .		2-26
Adjusting voltage control circuits . . . . .		2-20
Ammeter M2 . . . . .		2-29
<b>B</b>		
Block diagram analysis . . . . .		1-5
<b>C</b>		
Capacitor C1, C2 . . . . .		2-35
Chart, troubleshooting . . . . .		2-3
Circuit breaker CB1 . . . . .		2-27
Circuit card assembly PC 101(A1) . . . . .		2-26
Circuits, control . . . . .		1-8
Circuits, power and voltage . . . . .		1-6
Component testing . . . . .		2-14
Control circuits . . . . .		1-8
<b>D</b>		
DC voltage adjust components . . . . .		2-30
Description and data, equipment . . . . .		1-2
Destruction ofarmymaterielto prevent enemy use . . . . .		1-2
Diagram analysis, block . . . . .		1-5
Differences between models. . . . .		1-3
Diodes CRI, CR2,CR3,CR4,CR5. . . . .		2-32
Diode CR6 . . . . .		2-43
Diode SCR1 (Q1) . . . . .		2-37
Diode SCR2 (Q2) . . . . .		2-38
<b>E</b>		
Equipmentdescription anddata. . . . .		1-2
Equipment, purposeand use.. . . .		1-2
<b>F</b>		
Fan motor Be . . . . .		2-40
<b>I</b>		
Interlock switch . . . . .		2-43

INDEX - continued

SUBJECT	M	PAGE
Maintenance forms, records, and reports . . . . .		1-2
Maintenance procedures, direct support . . . . .		2-22
Removing and replacing panels . . . . .		2-22
Removing and replacing parts. . . . .		2-26
Maintenance procedures, general support . . . . .		3-6
Removing and replacing circuitcard assembly PC 101(A1) . . . . .		3-6
Repairing circuit card assembly. . . . .		3-6
Materials, repair parts,tools,test equipment . . . . .		2-1,3-2
Models, differences between.. . . . .		1-3
 <b>P</b> 		
Panels, removing and replacing . . . . .		2-22
Parts, removing and replacing. . . . .		2-26
Physical tests and inspections. . . . .		2-44
Powerand voltage circuits . . . . .		1-6
Procedures,troubleshooting,(direct support maintenance) . . . . .		2-2
Procedures, troubleshooting, (general support maintenance) . . . . .		3-3
Procedures, test . . . . .		2-44, 3-10
Principles of operation, technical . . . . .		1-5
 <b>R</b> 		
Reactor L2 . . . . .		2-34
Removing and repairingcircuitcard assembly PC 101(A1) . . . . .		3-6
Removing and replacing panels. . . . .		2-22
Removing and replacing parts. . . . .		2-26
Repair parts, tools, testequipment and materials,(direct support) . . . . .		2-1
Repair parts, tools, testequipment and materials, (general support). . . . .		3-2
Repairing circuit card assembly PC 101(A1) . . . . .		3-6
Reporting Equipment Improvement Recommendations (EIR) . . . . .		1-2
Resistor R3 . . . . .		2-37
 <b>S</b> 		
Safety, care, and handling . . . . .		1-4
Static voltage regulation test . . . . .		2-45
Symptom index . . . . .		2-3

INDEX - continued

SUBJECT	T	PAGE
Technical principles of operation . . . . .		1-5
Test data summary, (direct support) . . . . .		2-48
Test datasummary,(general support) . . . . .		3-13
Test Legend, (direct support) . . . . .		2-46
Test Legend, (generaisupport). . . . .		3-11
Test procedures,(direct support). . . . .		2-44
Test procedures, (general support) . . . . .		3-10
Testing, components . . . . .		2-14
Testing and troubleshooting circuit card assembly . . . . .		2-16
Troubleshooting,(direct support maintenance) . . . . .		2-2
Troubleshooting,(general support maintenance). . . . .		3-3
Troubleshooting chart . . . . .		2-3
Tools, repairparts, testequipment, materials . . . . .		2-1, 3-2
Transformer T1 . . . . .		2-41

V

Voltage and power circuits . . . . .	1-6
Voltage and resistance data . . . . .	2-18
Voltage control circuits,adjusting . . . . .	2-20
VoltmeterMI . . . . .	2-28





## FOLDOUT INDEX

**Figure FO-1** ①. Color Code Marking for Military Standard (sheet 1 of 2).

**Figure FO-1** ②. Color Code Marking for Military Standard (sheet 2 of 2).

**Figure FO-2** ①. Power Supply PP-4763/GRC (sheet 1 of 2).

**Figure FO-2** ②. Power Supply PP-4763/GRC (sheet 2 of 2).

**Figure FO-3** ①. Power Supply PP-4763A/GRC (sheet 1 of 2).

**Figure FO-3** ②. Power Supply PP-4763A/GRC (sheet 2 of 2).

ALL THE ABOVE LISTED FOLDOUTS ARE LOCATED IN THE BACK OF THE MANUAL.





THEN, JOT DOWN THE DOPE ABOUT IT ON THIS FORM. CAREFULLY TEAR IT OUT, FOLD IT AND DROP IT IN THE MAIL.

SOMETHING WRONG WITH THIS PUBLICATION?

FROM (PRINT YOUR UNIT'S COMPLETE ADDRESS)  
 Commander  
 Stateside Army Depot  
 ATTN: AMSTA-US  
 Stateside, N.J. 07703

DATE SENT  
 10 July 1975

PUBLICATION NUMBER  
 TM 11-5840-340-12

PUBLICATION DATE  
 23 Jan 74

PUBLICATION TITLE  
 Radar Set AN/PRC-76

BE EXACT PIN-POINT WHERE IT IS

PAGE NO	PARA. GRAPH	FIGURE NO	TABLE NO
2-25	2-28		
3-10	3-3		3-1
5-6	5-8		

IN THIS SPACE TELL WHAT IS WRONG AND WHAT SHOULD BE DONE ABOUT IT:

Recommend that the installation antenna alignment procedure be changed throughout to specify a 2° IFF antenna lag rather than 1°.

REASON: Experience has shown that with only a 1° lag, the antenna servo system is too sensitive to wind gusting in excess of 25 knots, and has a tendency to rapidly accelerate and decelerate as it hunts, causing strain to the drive train. Hunting is minimized by adjusting the lag to 2° without degradation of operation.

Item 5, Function column. Change "2 db" to "3db."

REASON: The adjustment procedure the the TRANS POWER FAULT indicator calls for a 3 db (500 watts) adjustment to light the TRANS POWER FAULT indicator.

Add new step f.1 to read, "Replace cover plate removed in step e.1, above."

REASON: To replace the cover plate.

Zone C 3. On J1-2, change "+24 VDC to "+5 VDC."

REASON: This is the output line of the 5 VDC power supply. +24 VDC is the input voltage.

11-4840-340-12-101

PRINTED NAME GRADE OR TITLE AND TELEPHONE NUMBER  
 SSG I. M. DeSpiritof 999-1776

SIGN HERE

FILL IN YOUR  
UNIT'S ADDRESS

FOLD BACK

DEPARTMENT OF THE ARMY

OFFICIAL BUSINESS

**SAMPLE**

Commander  
US Army Communications-Electronics Command  
and Fort Monmouth  
ATTN: DRSEL-ME-MP  
Fort Monmouth, New Jersey 07703

TEAR ALONG PERFORATED LINE



THEN...JOT DOWN THE DOPE ABOUT IT ON THIS FORM. CAREFULLY TEAR IT OUT, FOLD IT AND DROP IT IN THE MAIL.

**SOMETHING WRONG WITH THIS PUBLICATION?**

FROM: (PRINT YOUR UNIT'S COMPLETE ADDRESS)

DATE SENT

PUBLICATION NUMBER

TM 11-5820-765-34

PUBLICATION DATE

15 Aug. 83

PUBLICATION TITLE Power Supply

PP 4763/GRC & PP 4763A/GRC

BE EXACT PIN-POINT WHERE IT IS

PAGE NO.

PARA-GRAPH

FIGURE NO.

TABLE NO.

IN THIS SPACE TELL WHAT IS WRONG AND WHAT SHOULD BE DONE ABOUT IT:

TEAR ALONG PERFORATED LINE.

PRINTED NAME GRADE OR TITLE AND TELEPHONE NUMBER

SIGN HERE

FILL IN YOUR  
UNIT'S ADDRESS

FOLD BACK

DEPARTMENT OF THE ARMY

OFFICIAL BUSINESS

Commander  
US Army Communications-Electronics Command  
and Fort Monmouth  
ATTN: DRSEL-ME-MP  
Fort Monmouth, New Jersey 07703



FILL IN YOUR  
UNIT'S ADDRESS

FOLD BACK

DEPARTMENT OF THE ARMY

OFFICIAL BUSINESS

Commander  
US Army Communications-Electronics Command  
and Fort Monmouth  
ATTN: DRSEL-ME-MP  
Fort Monmouth, New Jersey 07703





THEN...JOT DOWN THE DOPE ABOUT IT ON THIS FORM. CAREFULLY TEAR IT OUT, FOLD IT AND DROP IT IN THE MAIL.

**SOMETHING WRONG WITH THIS PUBLICATION?**

FROM: (PRINT YOUR UNIT'S COMPLETE ADDRESS)

DATE SENT

PUBLICATION NUMBER

TM 11-5820-765-34

PUBLICATION DATE

15 Aug. 83

PUBLICATION TITLE Power Supply

PP 4763/GRC & PP 4763A/GRC

BE EXACT PIN-POINT WHERE IT IS

PAGE NO.	PARA-GRAPH	FIGURE NO.	TABLE NO.

IN THIS SPACE TELL WHAT IS WRONG AND WHAT SHOULD BE DONE ABOUT IT:

PRINTED NAME GRADE OR TITLE AND TELEPHONE NUMBER

SIGN HERE

TEAR ALONG PERFORATED LINE

FILL IN YOUR  
UNIT'S ADDRESS

FOLD BACK

DEPARTMENT OF THE ARMY

OFFICIAL BUSINESS

Commander  
US Army Communications-Electronics Command  
and Fort Monmouth  
ATTN: DRSEL-ME-MP  
Fort Monmouth, New Jersey 07703

By Order of the Secretary of the Army:

Official:

JOHN A. WICKHAM JR.  
*General, United States Army*  
*Chief of Staff*

ROBERT M. JOYCE  
*Major General, United States Army*  
*The Adjutant General*

DISTRIBUTION:

To be distributed in accordance with DA Form 12-51, Direct and General Support Maintenance requirements for PP-4763/GRC.



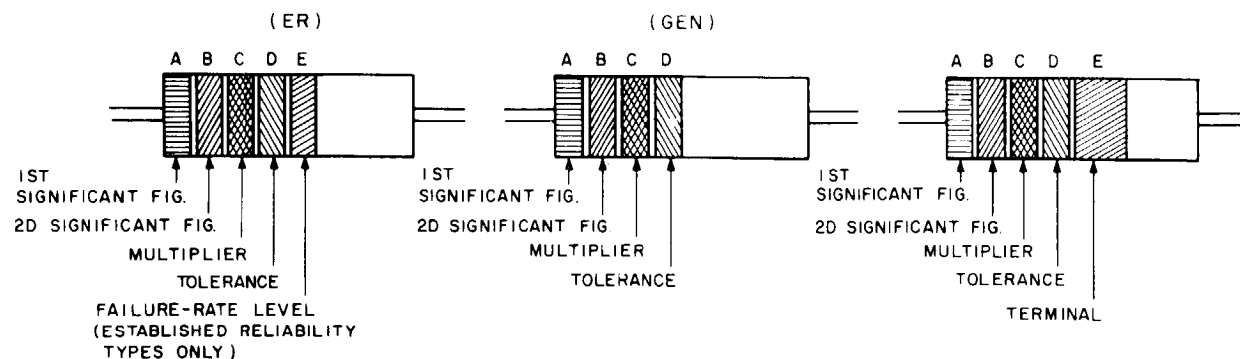

COLOR CODE MARKING FOR COMPOSITION TYPE RESISTORS.

COLOR-CODE MARKING FOR FILM-TYPE RESISTORS.

TABLE I  
COLOR CODE FOR COMPOSITION TYPE AND FILM TYPE RESISTORS.

BAND A		BAND B		BAND C		BAND D		BAND E		
COLOR	FIRST SIGNIFICANT FIGURE	COLOR	SECOND SIGNIFICANT FIGURE	COLOR	MULTIPLIER	COLOR	RESISTANCE TOLERANCE (PERCENT)	COLOR	FAILURE RATE LEVEL	TERM.
BLACK	0	BLACK	0	BLACK	1			BROWN	M=1.0	SOLD-ERABLE
BROWN	1	BROWN	1	BROWN	10			RED	P=0.1	
RED	2	RED	2	RED	100			ORANGE	R=0.01	
ORANGE	3	ORANGE	3	ORANGE	1,000			YELLOW	S=0.001	
YELLOW	4	YELLOW	4	YELLOW	10,000	SILVER	±10 (COMP. TYPE ONLY)	WHITE		
GREEN	5	GREEN	5	GREEN	100,000	GOLD	±5			
BLUE	6	BLUE	6	BLUE	1,000,000	RED	±2 (NOT APPLICABLE TO ESTABLISHED RELIABILITY)			
PURPLE (VIOLET)	7	PURPLE (VIOLET)	7							
GRAY	8	GRAY	8	SILVER	0.01					
WHITE	9	WHITE	9	GOLD	0.1					

- BAND A — THE FIRST SIGNIFICANT FIGURE OF THE RESISTANCE VALUE (BANDS A THRU D SHALL BE OF EQUAL WIDTH.)
- BAND B — THE SECOND SIGNIFICANT FIGURE OF THE RESISTANCE VALUE.
- BAND C — THE MULTIPLIER (THE MULTIPLIER IS THE FACTOR BY WHICH THE TWO SIGNIFICANT FIGURES ARE MULTIPLIED TO YIELD THE NOMINAL RESISTANCE VALUE.)
- BAND D — THE RESISTANCE TOLERANCE.
- BAND E — WHEN USED ON COMPOSITION RESISTORS, BAND E INDICATES ESTABLISHED RELIABILITY FAILURE-RATE LEVEL (PERCENT FAILURE PER 1,000 HOURS). ON FILM RESISTORS, THIS BAND SHALL BE APPROXIMATELY 1-1/2 TIMES THE WIDTH OF OTHER BANDS, AND INDICATES TYPE OF TERMINAL.

RESISTANCES IDENTIFIED BY NUMBERS AND LETTERS (THESE ARE NOT COLOR CODED)

SOME RESISTORS ARE IDENTIFIED BY THREE OR FOUR DIGIT ALPHA NUMERIC DESIGNATORS. THE LETTER R IS USED IN PLACE OF A DECIMAL POINT WHEN FRACTIONAL VALUES OF AN OHM ARE EXPRESSED. FOR EXAMPLE:

2R7 = 2.7 OHMS    10R0 = 10.0 OHMS

FOR WIRE-WOUND-TYPE RESISTORS COLOR CODING IS NOT USED, IDENTIFICATION MARKING IS SPECIFIED IN EACH OF THE APPLICABLE SPECIFICATIONS.

A. COLOR CODE MARKING FOR MILITARY STANDARD RESISTORS.

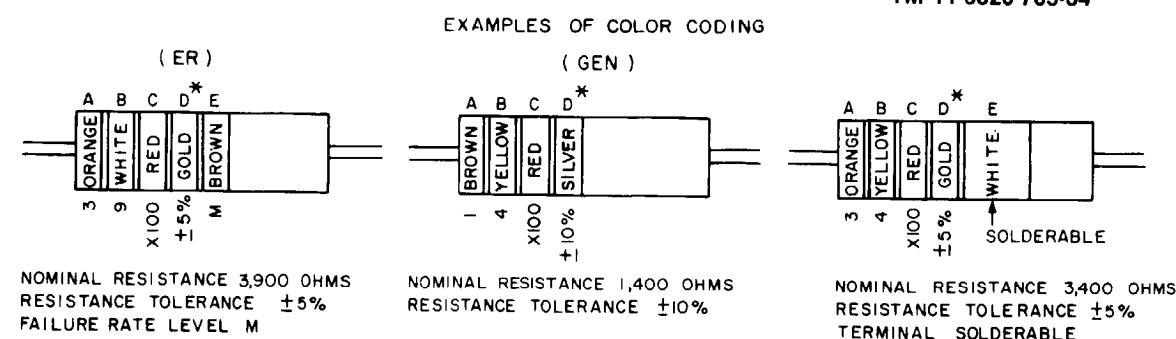

COMPOSITION-TYPE RESISTORS

FILM-TYPE RESISTORS

\* IF BAND D IS OMITTED, THE RESISTOR TOLERANCE IS ±20% AND THE RESISTOR IS NOT MIL-STD.

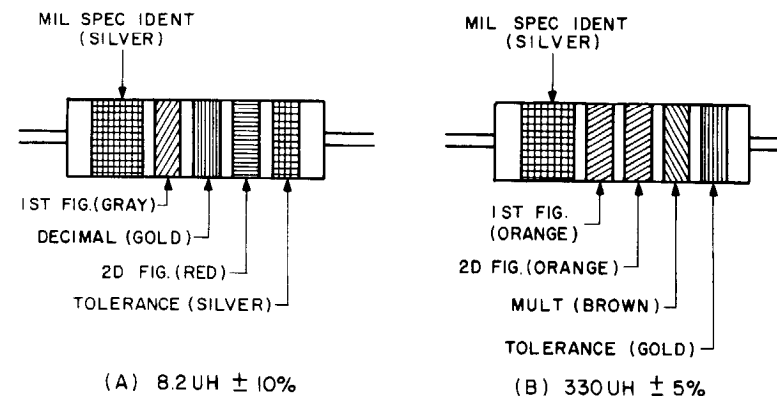

COLOR CODING FOR TUBULAR ENCAPSULATED R.F. CHOKES. AT A, AN EXAMPLE OF THE CODING FOR AN 8.2UH CHOKE IS GIVEN. AT B, THE COLOR BANDS FOR A 330UH INDUCTOR ARE ILLUSTRATED.

TABLE 2  
COLOR CODING FOR TUBULAR ENCAPSULATED R.F. CHOKES.

COLOR	SIGNIFICANT FIGURE	MULTIPLIER	INDUCTANCE TOLERANCE (PERCENT)
BLACK	0	1	
BROWN	1	10	1
RED	2	100	2
ORANGE	3	1,000	3
YELLOW	4		
GREEN	5		
BLUE	6		
VIOLET	7		
GRAY	8		
WHITE	9		
NONE			20
SILVER			10
GOLD	DECIMAL POINT		5

MULTIPLIER IS THE FACTOR BY WHICH THE TWO COLOR FIGURES ARE MULTIPLIED TO OBTAIN THE INDUCTANCE VALUE OF THE CHOKE COIL.

B. COLOR CODE MARKING FOR MILITARY STANDARD INDUCTORS.

RESISTORS AND INDUCTORS

Figure FO-1(1). Color Code Marking for Military Standard (sheet 1 of 2).

CAPACITOR COLOR CODE TABLES

TABLE I - For use with Group I, Styles CM, CN, CY and CB

COLOR	MIL ID	1st SIG FIG	2nd SIG FIG	MULTIPLIER <sup>1</sup>	CAPACITANCE TOLERANCE				CHARACTERISTIC <sup>2</sup>				DC WORKING VOLTAGE	OPERATING TEMP. RANGE	VIBRATION GRADE
					CM	CN	CY	CB	CM	CN	CY	CB			
BLACK	CM, CY, CB	0	0	1			± 20 %	± 20 %		A				55 ° to + 70 °C	10 - 55 cps
BROWN		1	1	10						B	E				
RED		2	2	100	± 2 %		± 2 %	± 2 %		C		C		-55 ° to + 85 °C	
ORANGE		3	3	1,000		± 30 %				D			300		
YELLOW		4	4	10,000						E		D		-55 ° to + 125 °C	10 - 200 cps
GREEN		5	5			± 5 %				F			500		
BLUE		6	6											-55 ° to + 150 °C	
PURPLE (VIOLET)		7	7												
GREY		8	8												
WHITE		9	9												
GOLD				0.1			± 5 %	± 5 %							
SILVER	CN				± 10 %	± 10 %	± 10 %	± 10 %							

TABLE II - For use with Group II, General Purposes, Style CK

COLOR	TEMP. RANGE AND VOLTAGE - TEMP LIMITS <sup>2</sup>	1st SIG FIG	2nd SIG FIG	MULTIPLIER <sup>1</sup>	CAPACITANCE TOLERANCE	MIL ID
BLACK		0	0	1	± 20 %	
BROWN	AW	1	1	10	± 10 %	
RED	AX	2	2	100		
ORANGE	BX	3	3	1,000		
YELLOW	AV	4	4	10,000		CK
GREEN	CZ	5	5			
BLUE	BV	6	6			
PURPLE (VIOLET)		7	7			
GREY		8	8			
WHITE		9	9			
GOLD						
SILVER						

TABLE III - For use with Group III, Temperature Compensating, Style CC

COLOR	TEMPERATURE COEFFICIENT <sup>4</sup>	1st SIG FIG	2nd SIG FIG	MULTIPLIER <sup>1</sup>	CAPACITANCE TOLERANCE		MIL ID
					CAPACITANCES OVER 10uuf	CAPACITANCES 10uuf OR LESS	
BLACK	0	0	0	1		± 2.0uuf	CC
BROWN	-30	1	1	10		± 1 %	
RED	-80	2	2	100		± 2 %	± 0.25uuf
ORANGE	-150	3	3	1,000			
YELLOW	-220	4	4				
GREEN	-330	5	5			± 5 %	± 0.5uuf
BLUE	-470	6	6				
PURPLE (VIOLET)	-750	7	7	0.01			
GREY		8	8	0.1	± 10 %		
WHITE		9	9				
GOLD	+100					± 1.0uuf	
SILVER							

- The multiplier is the number by which the two significant (SIG) figures are multiplied to obtain the capacitance in uuf.
- Letter indicate the Characteristics designated in applicable specifications: MIL-C-5, MIL-C-91, MIL-C-11272, and MIL-C-10950 respectively.
- Letters indicate the temperature range and voltage-temperature limits designated in MIL-C-11015.
- Temperature coefficient in parts per million per degree centigrade.

COLOR CODE MARKING FOR MILITARY STANDARD CAPACITORS

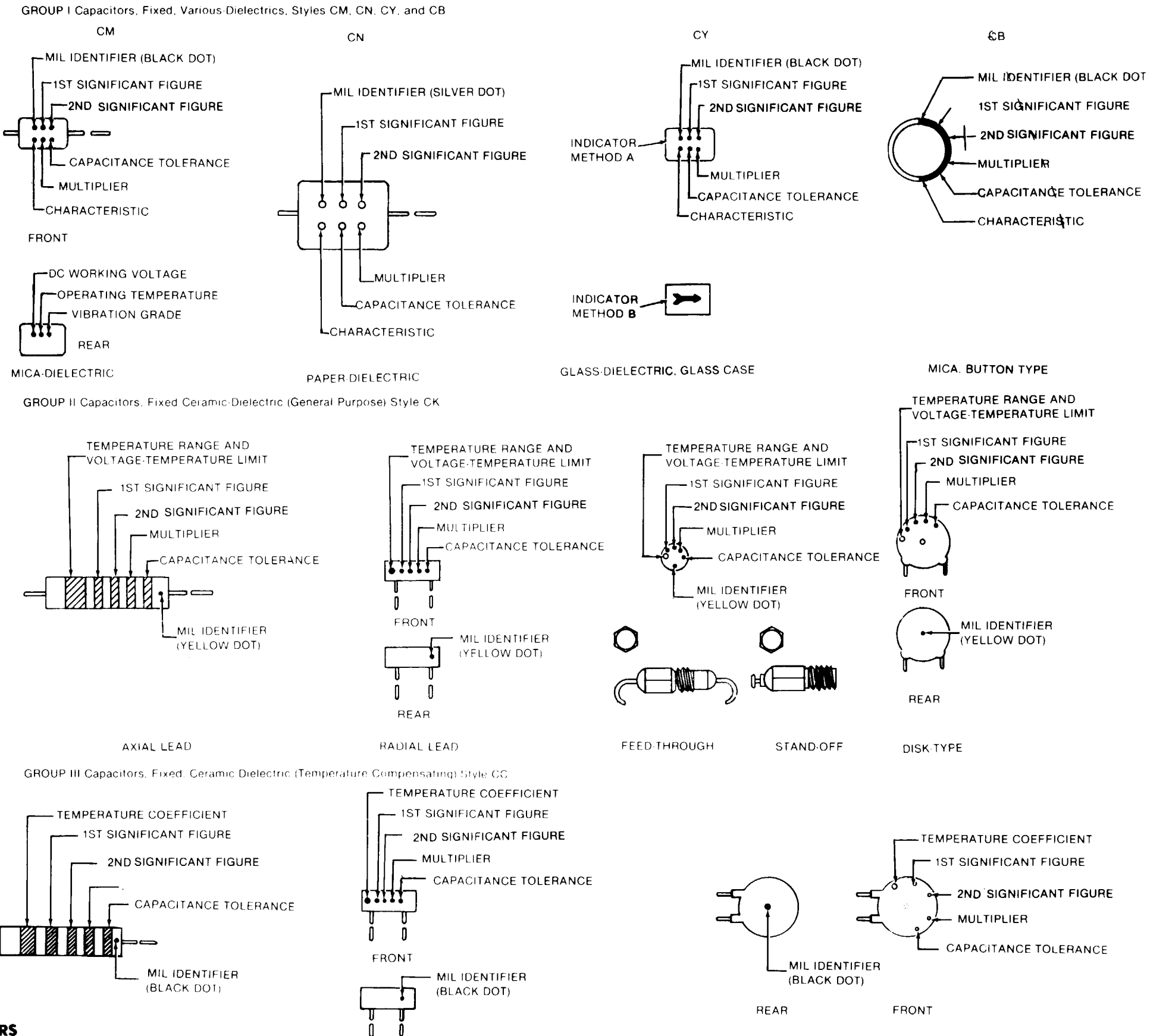

CAPACITORS

Figure FO-1 (2). Color Code Marking for Military Standard (sheet 2 of 2).

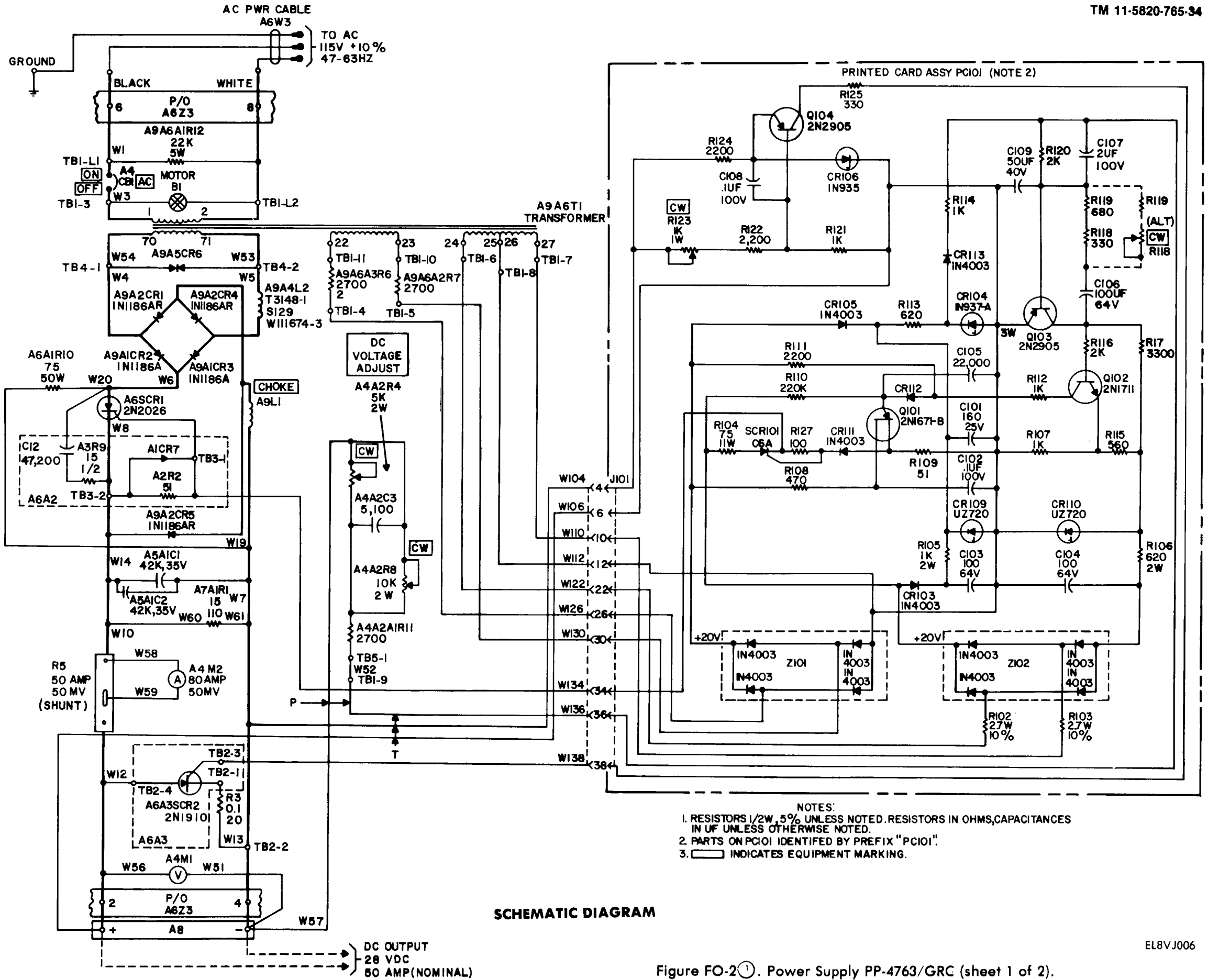

Figure FO-2 (1). Power Supply PP-4763/GRC (sheet 1 of 2).

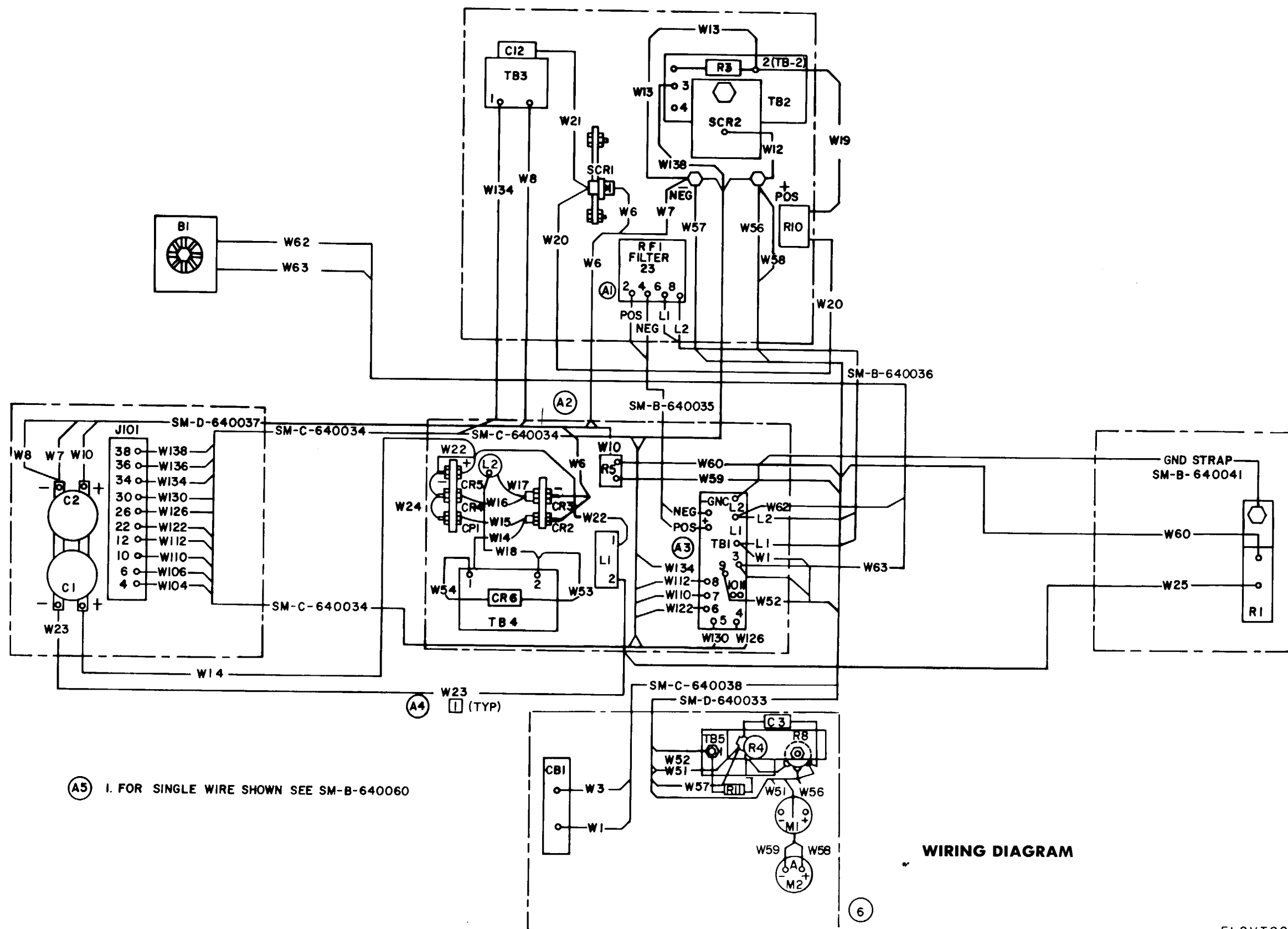
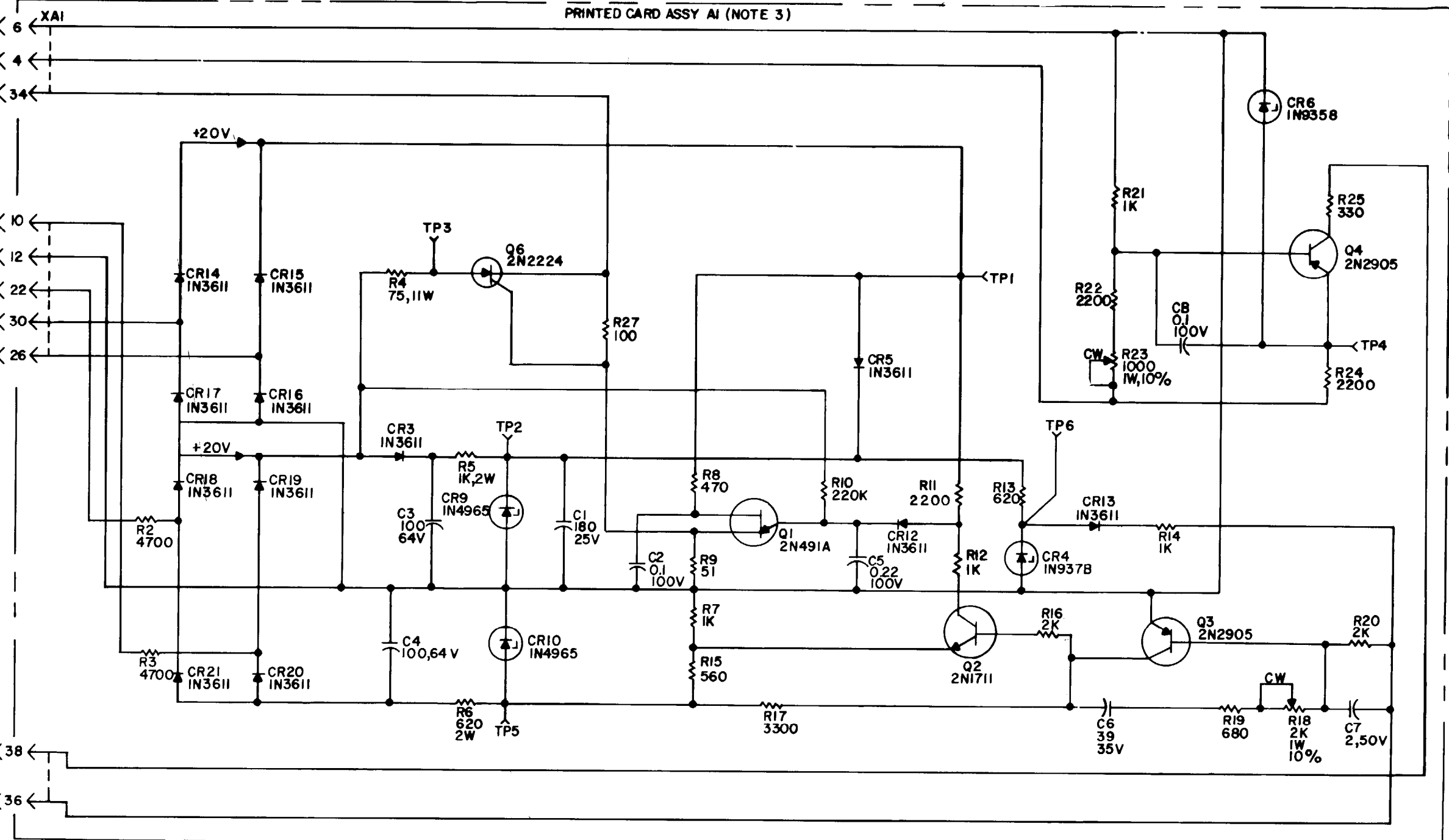
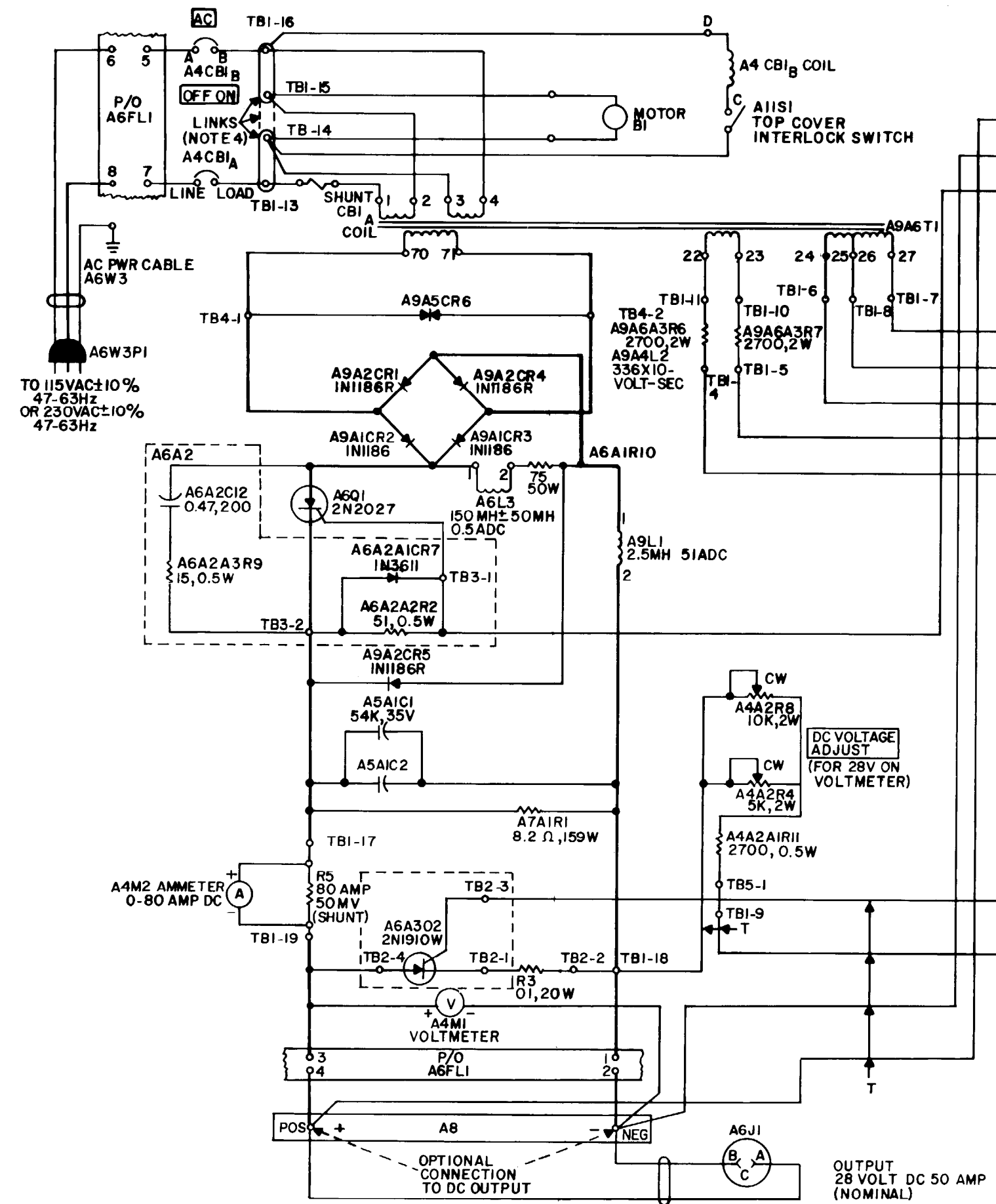

Figure FO-2(2). Power Supply PP-4763/GRC (sheet 2 of 2).





- NOTES:
1. ALL RESISTOR VALUES ARE OHMS 0.5W 5% UNLESS OTHERWISE NOTED.
  2. ALL CAPACITOR VALUES ARE IN UF.
  3. PARTS ON AI IDENTIFIED BY PREFIX "AI"
  4. LINKS SHOWN FOR 115-VOLT INPUT FOR 230-VOLT INPUT BOTH LINKS ARE POSITIONED AS SHOWN BY DASHED LINES.
  5. [ ] INDICATES EQUIPMENT MARKING.

**SCHEMATIC DIAGRAM**

Figure FO-3(1). Power Supply PP-4763A/GRC (sheet 1 of 2).

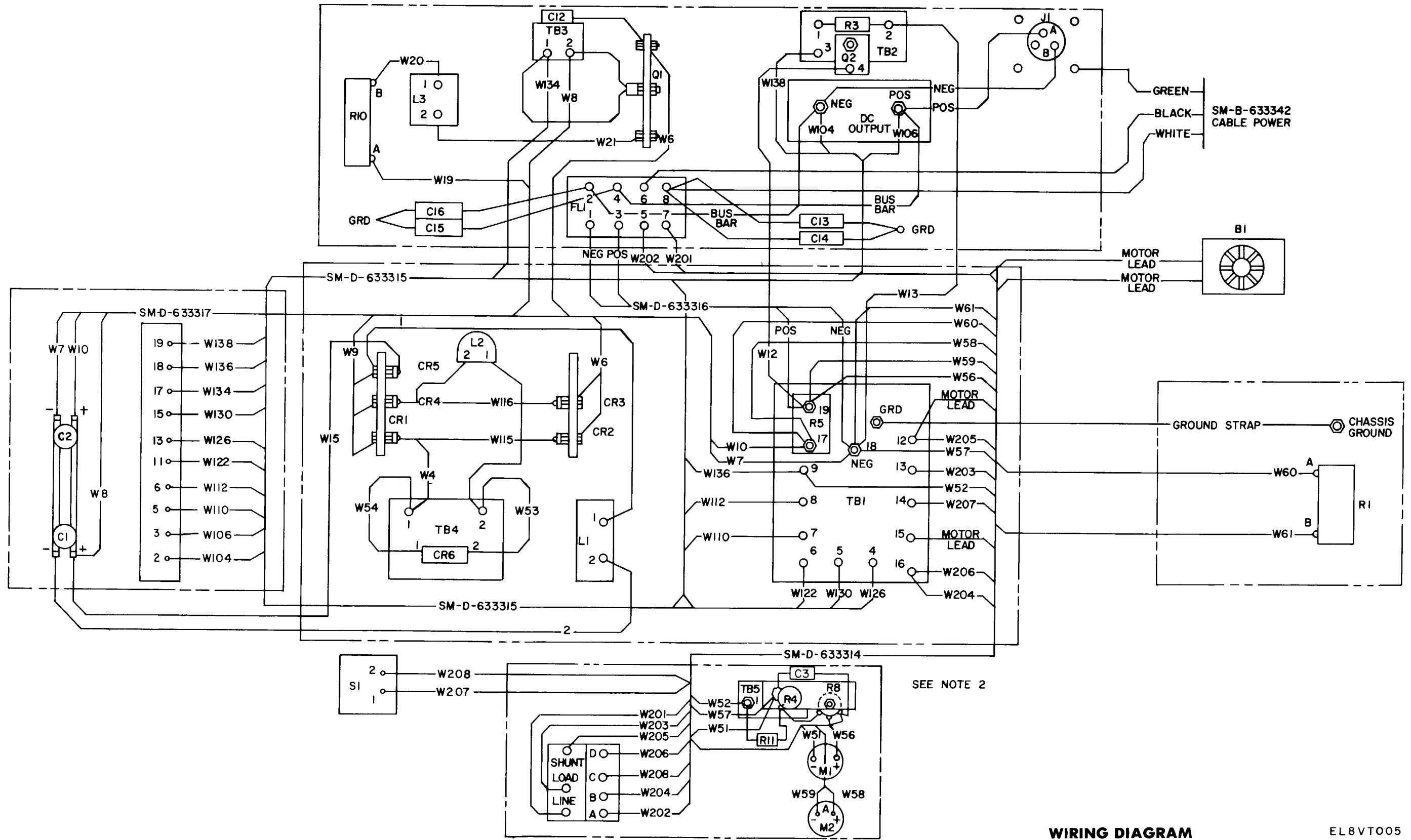

**WIRING DIAGRAM**

EL8VT005

Figure FO-3<sup>(2)</sup>. Power Supply PP-4763A/GRC (sheet 2 of 2).



